

# PV\_\_-7,62-H-P-S

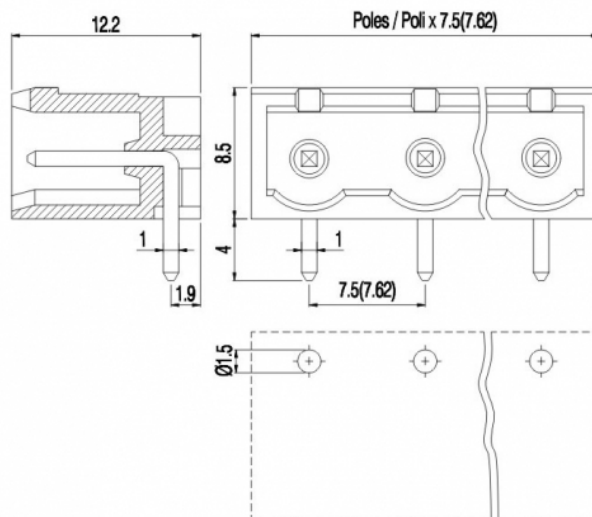
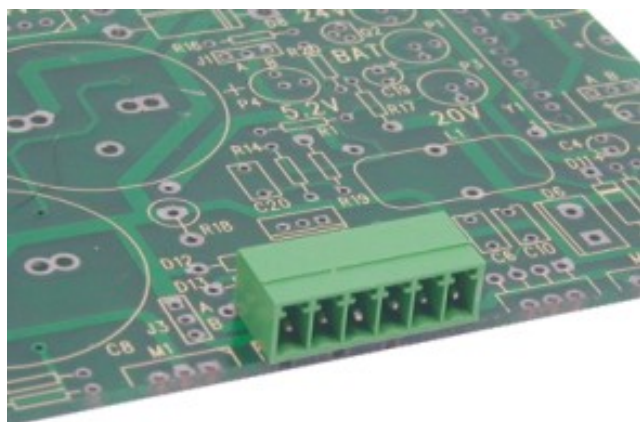

## GENERAL INFORMATION

pitch	7,62 mm
Height	7.25 mm
Depth	9.2 mm
Dimensional class	Bassa
Wire section	-
Clamp opening size	-
Wire stripping	-
Operating temperature	-40 ÷ +130 °C

## ELECTRICAL CHARACTERISTICS

Current	11 A
Voltage	500 V
impulse voltage	6 kV

## MECHANICAL CHARACTERISTICS

Screw	-
Recommended torque	-

## APPROVALS DATA



Current	-	EN 61984	11 A	UL 1059	11 A factory / 11 A field
Voltage	-		400 V		300 V
Wire section	-		-		-
Torque	-		-		-
FILE	-		40048261		E178356

## MATERIALS

Housing	PA - UL 94 V0
Screw	-
Clamp	-
Terminal	Tin-plated copper alloy
SCIP Number	892ed63d-670d-4367-9365-34dfcaff593c

**COLOURS**

Standard



On request



POLES	NAME	3D FILE
02	PV02-7,62-H-P-S	File available
03	PV03-7,62-H-P-S	File not available for this product
04	PV04-7,62-H-P-S	File not available for this product
05	PV05-7,62-H-P-S	File not available for this product
06	PV06-7,62-H-P-S	File not available for this product
07	PV07-7,62-H-P-S	File not available for this product
08	PV08-7,62-H-P-S	File not available for this product
09	PV09-7,62-H-P-S	File not available for this product
10	PV10-7,62-H-P-S	File not available for this product
11	PV11-7,62-H-P-S	File not available for this product
12	PV12-7,62-H-P-S	File not available for this product