

# PV\_\_-3,81-V-P

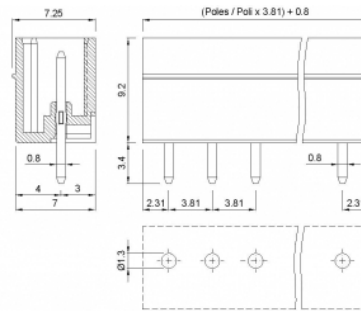
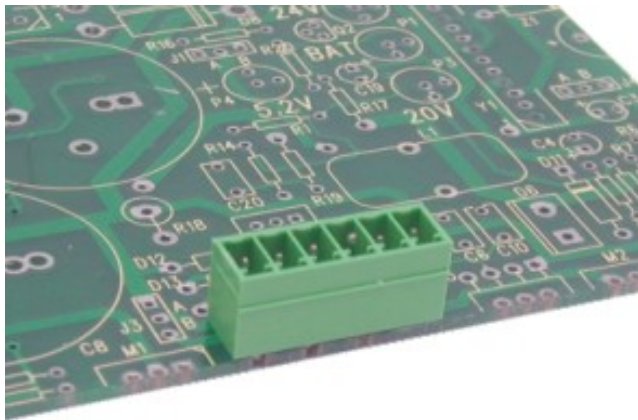

## GENERAL INFORMATION

pitch	3,81 mm
Height	9.2 mm
Depth	7.25 mm
Dimensional class	Bassa
Wire section	-
Clamp opening size	-
Wire stripping	-
Operating temperature	-40 ÷ +130 °C

## ELECTRICAL CHARACTERISTICS

Current	11 A
Voltage	160 V
impulse voltage	2.5 kV

## MECHANICAL CHARACTERISTICS

Screw	-
Recommended torque	-

## APPROVALS DATA



		EN 61984	UL 1059
Current	-	11 A	11 A factory / 11 A field
Voltage	-	200 V	300 V
Wire section	-	-	-
Torque	-	-	-
FILE	-	40048261	E178356

## MATERIALS

Housing	PA - UL 94 V0
Screw	-
Clamp	-
Terminal	Tin-plated copper alloy
SCIP Number	892ed63d-670d-4367-9365-34dfcaff593c

## COLOURS

Standard

On request



POLES	NAME	3D FILE
02	PV02-3,81-V-P	File available
03	PV03-3,81-V-P	File available
04	PV04-3,81-V-P	File available
05	PV05-3,81-V-P	File available
06	PV06-3,81-V-P	File available
07	PV07-3,81-V-P	File available
08	PV08-3,81-V-P	File available
09	PV09-3,81-V-P	File available
10	PV10-3,81-V-P	File available
11	PV11-3,81-V-P	File available
12	PV12-3,81-V-P	File available
13	PV13-3,81-V-P	File not available for this product
14	PV14-3,81-V-P	File not available for this product
15	PV15-3,81-V-P	File not available for this product
16	PV16-3,81-V-P	File not available for this product
17	PV17-3,81-V-P	File not available for this product
18	PV18-3,81-V-P	File not available for this product
19	PV19-3,81-V-P	File not available for this product
20	PV20-3,81-V-P	File not available for this product
21	PV21-3,81-V-P	File not available for this product
22	PV22-3,81-V-P	File not available for this product
23	PV23-3,81-V-P	File not available for this product
24	PV24-3,81-V-P	File not available for this product