

PV__-10-H

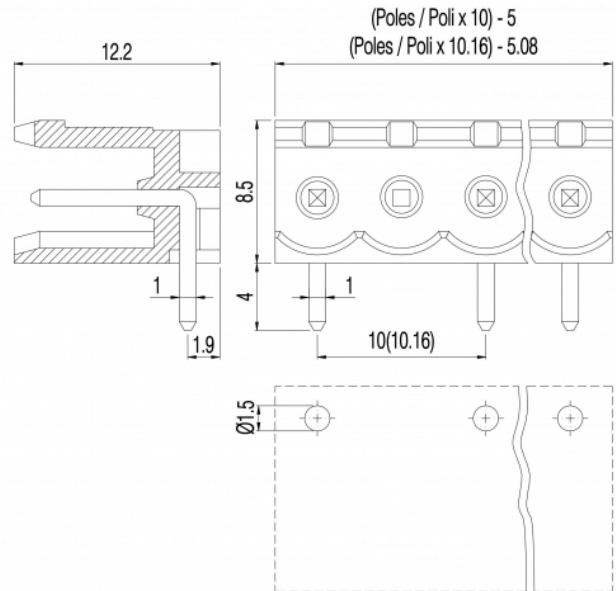
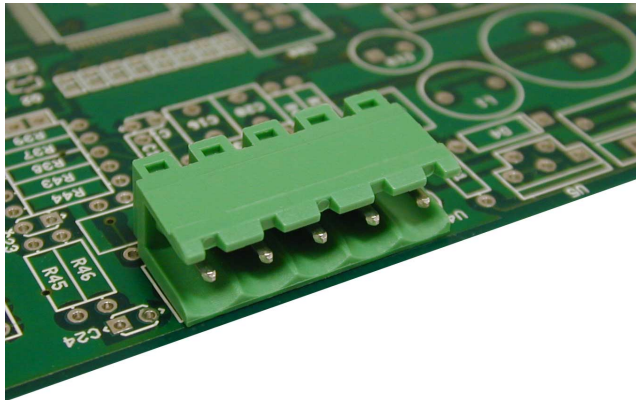

GENERAL INFORMATION

pitch	10 mm
Height	8.5 mm
Depth	12.2 mm
Dimensional class	Media
Wire section	-
Clamp opening size	-
Wire stripping	-
Operating temperature	-40 ÷ +130 °C

ELECTRICAL CHARACTERISTICS

Current	15 A
Voltage	500 V
impulse voltage	6 kV

MECHANICAL CHARACTERISTICS

Screw	-
Recommended torque	-

APPROVALS DATA



	EN 61984	EN 61984	UL 1059
Current	15 A	15 A	12 A factory / 12 A field
Voltage	500 V	500 V	600 V
Wire section	-	-	-
Torque	-	-	-
FILE	CA02.04178	40005779	E178356

MATERIALS

Housing	PA - UL 94 V0
Screw	-
Clamp	-

Terminal

Tin-plated copper alloy

COLOURS

Standard

On request



POLES	NAME	3D FILE
02	PV02-10-H	File not available for this product
03	PV03-10-H	File not available for this product
04	PV04-10-H	File not available for this product
05	PV05-10-H	File not available for this product
06	PV06-10-H	File not available for this product
07	PV07-10-H	File not available for this product
08	PV08-10-H	File not available for this product
09	PV09-10-H	File not available for this product
10	PV10-10-H	File not available for this product
11	PV11-10-H	File not available for this product
12	PV12-10-H	File not available for this product