

PDV1__-3,81-H-P

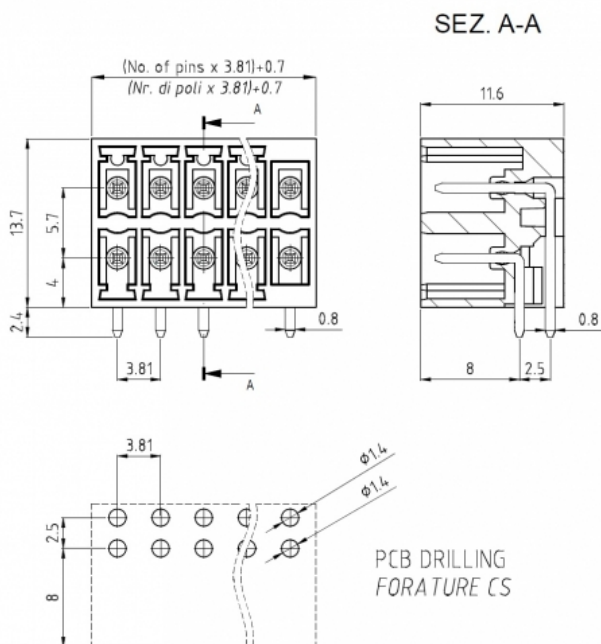
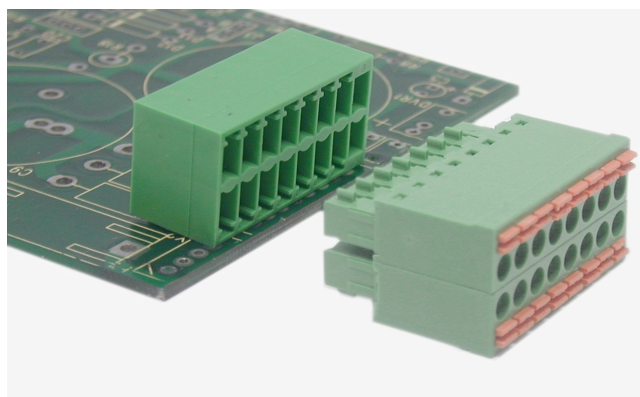

GENERAL INFORMATION

pitch	3,81 mm
Height	11.6 mm
Depth	13.7 mm
Dimensional class	Media
Wire section	-
Clamp opening size	-
Wire stripping	-
Operating temperature	-40 ÷ +130 °C

ELECTRICAL CHARACTERISTICS

Current	8 A
Voltage	160 V
Test Voltage	2.5 kVrms/60s

MECHANICAL CHARACTERISTICS

Screw	-
Recommended torque	-

APPROVALS DATA



Current	-	-	-
Voltage	-	-	-
Wire section	-	-	-
Torque	-	-	-
FILE	-	-	-

MATERIALS

Housing	PA - UL 94 V0
Screw	-

Tin-plated copper alloy

Clamp
Terminal
COLOURS



On request



POLES

- 02
- 03
- 04
- 05
- 06
- 07
- 08
- 09
- 10
- 11
- 12
- 13
- 14
- 15
- 16
- 17
- 18
- 19
- 20

NAME

- PDV102-3,81-H-P
- PDV103-3,81-H-P
- PDV104-3,81-H-P
- PDV105-3,81-H-P
- PDV106-3,81-H-P
- PDV107-3,81-H-P
- PDV108-3,81-H-P
- PDV109-3,81-H-P
- PDV110-3,81-H-P
- PDV111-3,81-H-P
- PDV112-3,81-H-P
- PDV113-3,81-H-P
- PDV114-3,81-H-P
- PDV115-3,81-H-P
- PDV116-3,81-H-P
- PDV117-3,81-H-P
- PDV118-3,81-H-P
- PDV119-3,81-H-P
- PDV120-3,81-H-P

3D FILE

- File not available for this product
- File not available for this product
- File not available for this product
- File not available for this product
- File not available for this product
- File not available for this product
- File not available for this product
- File not available for this product
- File not available for this product
- File not available for this product
- File not available for this product
- File not available for this product
- File not available for this product
- File not available for this product
- File not available for this product
- File not available for this product
- File not available for this product
- File not available for this product
- File not available for this product