

# PDV\_\_-7-V-P

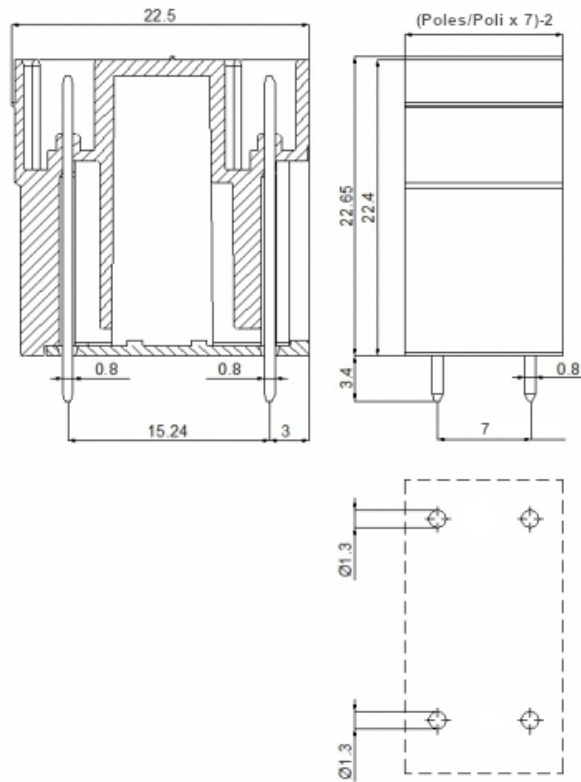
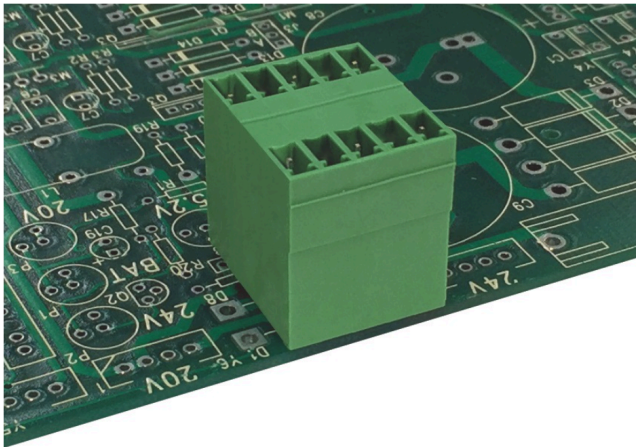

## GENERAL INFORMATION

pitch	7 mm
Height	22.65 mm
Depth	22.5 mm
Dimensional class	Media
Wire section	-
Clamp opening size	-
Wire stripping	-
Operating temperature	-40 ÷ +130 °C

## ELECTRICAL CHARACTERISTICS

Current	8 A
Voltage	400 V
impulse voltage	6 kV

## MECHANICAL CHARACTERISTICS

Screw	-
Recommended torque	-

## APPROVALS DATA



Current	-	EN 61984	8 A	UL 1059	11 A factory / 11 A field
Voltage	-		400 V		150V (C) V
Wire section	-		-		-

Torque - - -  
FILE - 40048261 E178356

**MATERIALS**

Housing PA - UL 94 V0  
Screw -  
Clamp -  
Terminal Tin-plated copper alloy

**COLOURS**

Standard



On request



**POLES** **NAME** **3D FILE**

02 PDV02-7-V-P File not available for this product