

# MVST25\_-5,08-W

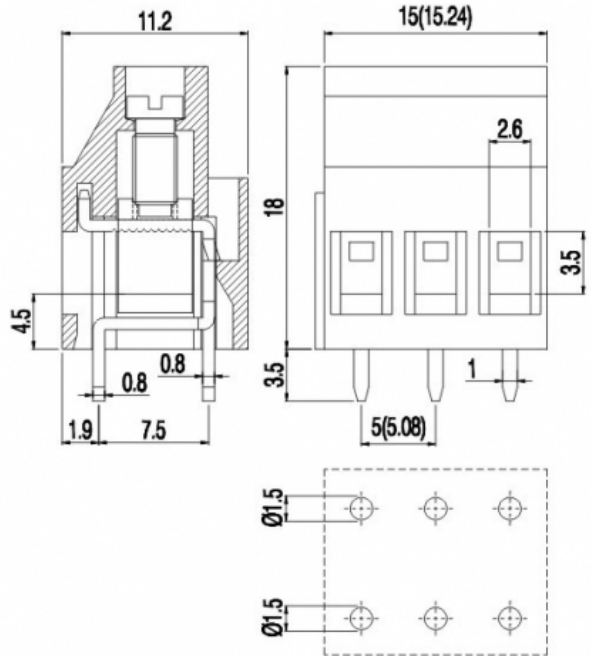
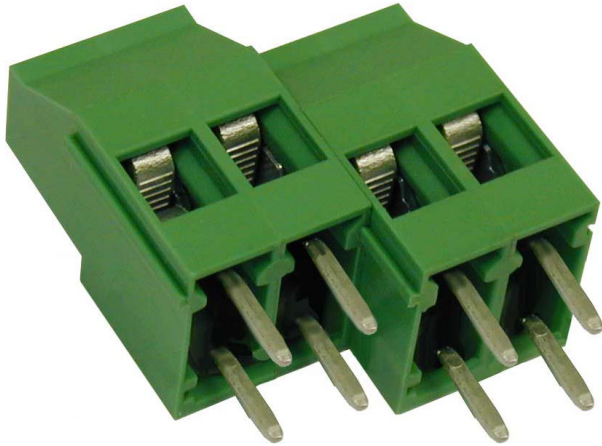

## GENERAL INFORMATION

pitch	5,08 mm
Height	18 mm
Depth	11.2 mm
Dimensional class	Media
Wire section	2.5 mm <sup>2</sup> / 14 AWG
Clamp opening size	2.8 x 3.5 mm
Wire stripping	max 9 mm
Operating temperature	-40 ÷ +105 °C

## ELECTRICAL CHARACTERISTICS

Current	24 A
Voltage	250 V
impulse voltage	2 kV

## MECHANICAL CHARACTERISTICS

Screw	M2.5
Recommended torque	0.4÷0.44 Nm / 3.5÷3.9 in.lbs

## APPROVALS DATA



Current	-	-	<b>UL 1059</b>
Voltage	-	-	20 A factory / - A field
Wire section	-	-	300 V
Torque	-	-	12 AWG
FILE	-	-	3.5 Lb-in
			E178356

## MATERIALS

Housing  
Screw  
Clamp  
Terminal

PA - UL 94 V0  
Galvanized steel  
Nickel-plated copper alloy  
Tin-plated copper alloy

**COLOURS**

Standard

On request



**POLES**

**NAME**

**3D FILE**

2	MVST252-5,08-W	File not available for this product
3	MVST253-5,08-W	File not available for this product