

MVS15_-5,08-H-L

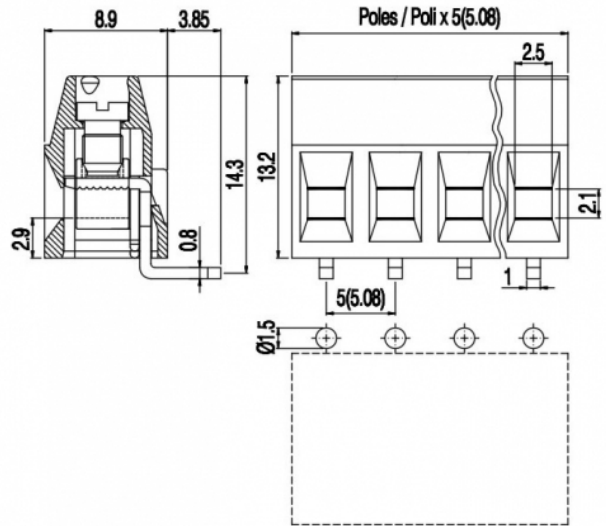
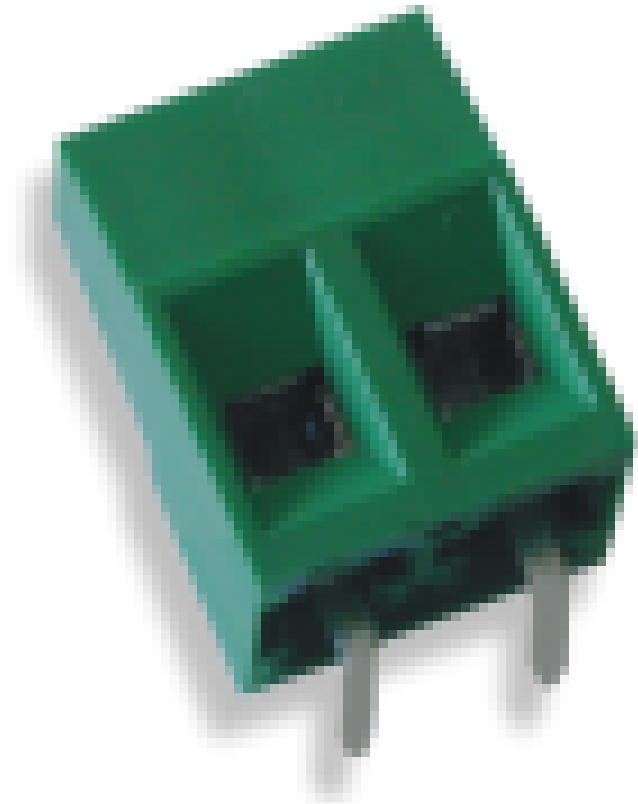

GENERAL INFORMATION

pitch	5,08 mm
Height	13.2 mm
Depth	8.9 mm
Dimensional class	Bassa
Wire section	1.5 mm ² / 16 AWG
Clamp opening size	2.5 x 2.1 mm
Wire stripping	max 7 mm
Operating temperature	-40 ÷ +130 °C

ELECTRICAL CHARACTERISTICS

Current	17.5 A
Voltage	450 V
impulse voltage	2.5 kV

MECHANICAL CHARACTERISTICS

Screw	M3
Recommended torque	0.5÷0.55 Nm / 4.5÷4.9 in.lbs

APPROVALS DATA



	EN 60998-1		UL 1059
Current	17.5 A	-	17.5 A factory / 10 A field
Voltage	450 V	-	300 V
Wire section	1.5 mm ²	-	16 AWG

Torque 0.5 Nm - 4.5 Lb-in
 FILE CA02.00598 - E178356

MATERIALS

Housing PA - UL 94 V0
 Screw Galvanized steel
 Clamp Nickel-plated copper alloy
 Terminal Tin-plated copper alloy
 SCIP Number 713ad43e-8dff-4607-9cfa-843d4a730153

COLOURS

Standard



On request



POLES	NAME	3D FILE
2	MVS152-5,08-H-L	File available
3	MVS153-5,08-H-L	File not available for this product
4	MVS154-5,08-H-L	File not available for this product
5	MVS155-5,08-H-L	File not available for this product
6	MVS156-5,08-H-L	File not available for this product
7	MVS157-5,08-H-L	File not available for this product
8	MVS158-5,08-H-L	File not available for this product
9	MVS159-5,08-H-L	File not available for this product
10	MVS1510-5,08-H-L	File not available for this product
11	MVS1511-5,08-H-L	File not available for this product
12	MVS1512-5,08-H-L	File not available for this product