

MVS13_-3,81-H

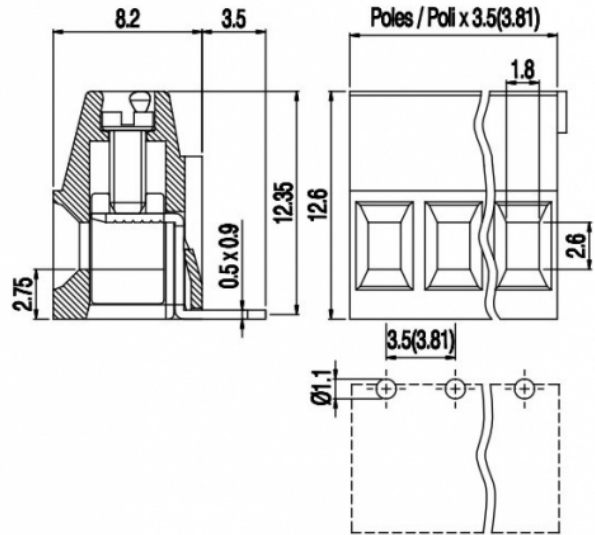

GENERAL INFORMATION

pitch	3,81 mm
Height	12.6 mm
Depth	8.2 mm
Dimensional class	Bassa
Wire section	1.5 mm ² / 16 AWG
Clamp opening size	1.8 x 2.6 mm
Wire stripping	max 6 mm
Operating temperature	-40 ÷ +130 °C

ELECTRICAL CHARACTERISTICS

Current	13,5 A
Voltage	130 V
impulse voltage	1.25 kV

MECHANICAL CHARACTERISTICS

Screw	M2
Recommended torque	0.2÷0.22 Nm / 1.8÷2 in.lbs

APPROVALS DATA



	EN 60998-1		UL 1059
Current	17.5 A	-	12 A factory / 10 A field
Voltage	130 V	-	150 V
Wire section	1.5 mm ²	-	16 AWG
Torque	0.2 Nm	-	1.8 Lb-in
FILE	CA02.04718	-	E178356

MATERIALS

Housing	PA - UL 94 V0
---------	---------------

Screw	Galvanized steel
Clamp	Tin-plated copper alloy
Terminal	Tin-plated copper alloy
SCIP Number	44bdd228-db28-48a8-9c38-13f7c55006ec

COLOURS



POLES	NAME	3D FILE
2	MVS132-3,81-H	File not available for this product
3	MVS133-3,81-H	File not available for this product
4	MVS134-3,81-H	File not available for this product
5	MVS135-3,81-H	File not available for this product
6	MVS136-3,81-H	File not available for this product
7	MVS137-3,81-H	File not available for this product
8	MVS138-3,81-H	File not available for this product
9	MVS139-3,81-H	File not available for this product
10	MVS1310-3,81-H	File not available for this product
11	MVS1311-3,81-H	File not available for this product
12	MVS1312-3,81-H	File not available for this product