

MVE27_-7,5-HR

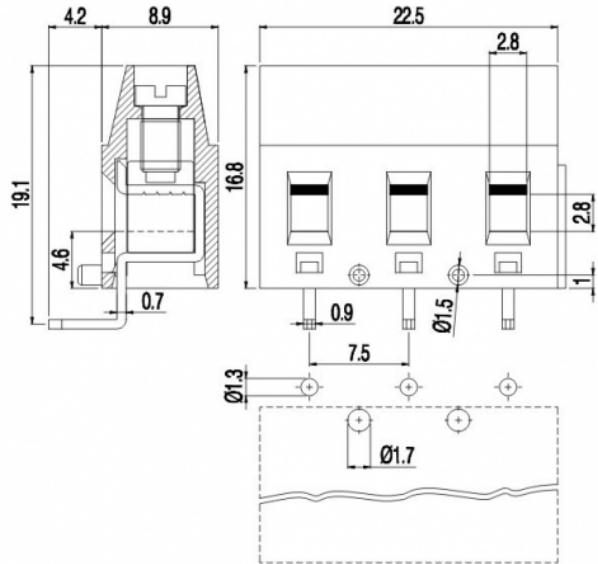

GENERAL INFORMATION

pitch	7,5 mm
Height	16.8 mm
Depth	8.9 mm
Dimensional class	Media
Wire section	2.5 mm ² / 14 AWG
Clamp opening size	2.8 x 2.8 mm
Wire stripping	max 7 mm
Operating temperature	-40 ÷ +130 °C

ELECTRICAL CHARACTERISTICS

Current	16 A
Voltage	750 V
impulse voltage	2.5 kV

MECHANICAL CHARACTERISTICS

Screw	M3
Recommended torque	0.5÷0.55 Nm / 4.5÷4.9 in.lbs

APPROVALS DATA



	EN 60998-1	EN 60998-1	UL 1059
Current	16 A	16 A	16 A factory / 15 A field
Voltage	750 V	750 V	300 V
Wire section	2.5 mm ²	2.8 mm ²	14 AWG
Torque	0.5 Nm	0.5 Nm	4.5 Lb-in
FILE	EP149	40023956	E178356

MATERIALS

Housing	PA - UL 94 V0
Screw	Galvanized steel
Clamp	Nickel-plated copper alloy
Terminal	Tin-plated copper alloy

SCIP Number

2821ab7c-15ea-41b0-a34a-7944c0ffffed

COLOURS

Standard

On request



POLES

NAME

3D FILE

2
3

MVE272-7,5-HR
MVE273-7,5-HR

File not available for this product
File not available for this product