

MV47_-15,24-H

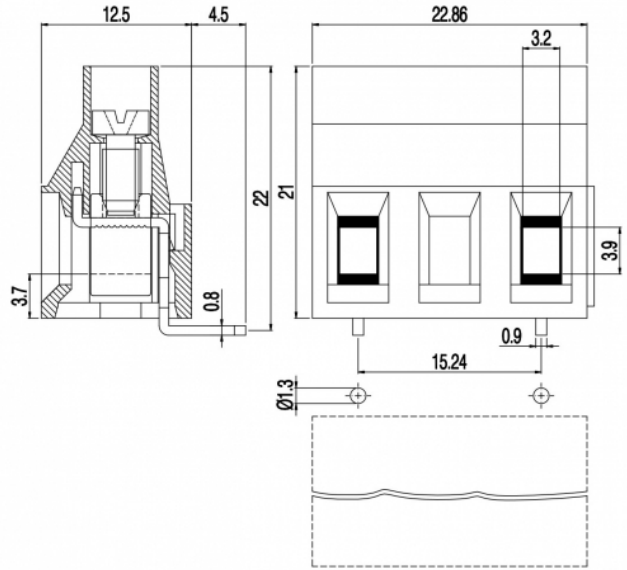

GENERAL INFORMATION

pitch	15,24 mm
Height	21 mm
Depth	12.5 mm
Dimensional class	Alta
Wire section	6.0 mm ² / 10 AWG
Clamp opening size	3.2 x 3.9 mm
Wire stripping	max 9 mm
Operating temperature	-40 ÷ +130 °C

ELECTRICAL CHARACTERISTICS

Current	32 A
Voltage	750 V
impulse voltage	3 kV

MECHANICAL CHARACTERISTICS

Screw	M3
Recommended torque	0.8÷0.88 Nm / 7.2÷7.9 in.lbs

APPROVALS DATA



	EN 60998-1	EN 60998-1	UL 1059
Current	32 A	25 A	30 A factory / 30 A field
Voltage	750 V	750 V	600 V
Wire section	6.0 mm ²	4.0 mm ²	10 AWG
Torque	0.8 Nm	0.5 Nm	7.2 Lb-in
FILE	EP150	40014734	E178356

MATERIALS

Housing	PA - UL 94 V0
Screw	Galvanized steel
Clamp	Nickel-plated copper alloy

Terminal
SCIP Number

Tin-plated copper alloy
1ccab36c-9cb5-4ef6-835d-596171944461

COLOURS

Standard



On request



POLES

NAME

3D FILE

1	MV471-15,24-H	File not available for this product
2	MV472-15,24-H	File not available for this product
3	MV473-15,24-H	File not available for this product
4	MV474-15,24-H	File not available for this product
5	MV475-15,24-H	File not available for this product
6	MV476-15,24-H	File not available for this product