

MV46_-12,7-IT

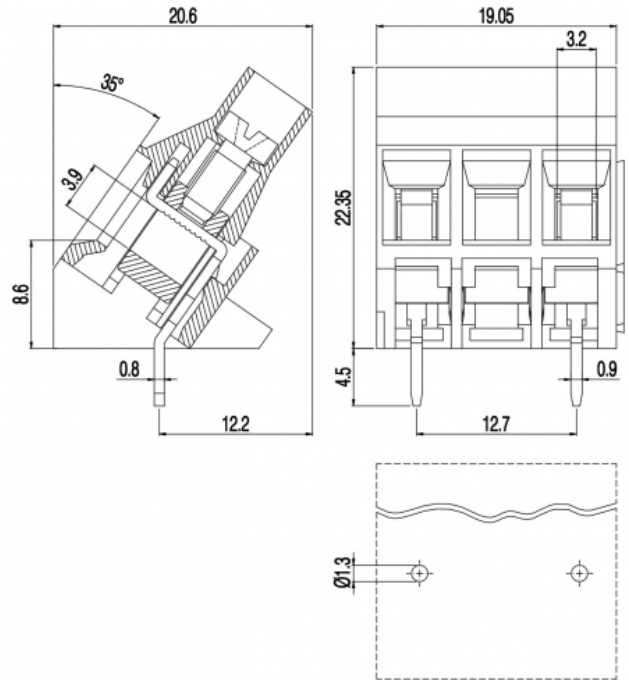
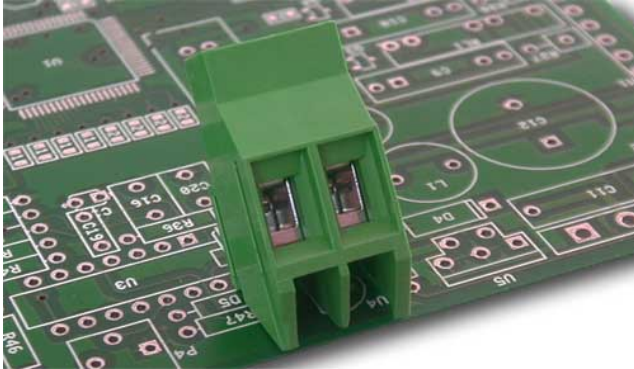

GENERAL INFORMATION

pitch	12,7 mm
Height	22.35 mm
Depth	20.6 mm
Dimensional class	Alta
Wire section	6.0 mm ² / 10 AWG
Clamp opening size	3.2 x 3.9 mm
Wire stripping	max 9 mm
Operating temperature	-40 ÷ +130 °C

ELECTRICAL CHARACTERISTICS

Current	32 A
Voltage	750 V
impulse voltage	3 kV

MECHANICAL CHARACTERISTICS

Screw	M3
Recommended torque	0.8÷0.88 Nm / 7.2÷7.9 in.lbs

APPROVALS DATA



	EN 60998-1	EN 60998-1	UL 1059
Current	32 A	32 A	30 A factory / 30 A field
Voltage	450 V	450 V	300 V
Wire section	6.0 mm ²	4.0 mm ²	10 AWG
Torque	0.8 Nm	0.5 Nm	7.2 Lb-in
FILE	EP150	40014734	E178356

MATERIALS

Housing	PA - UL 94 V0
---------	---------------

Screw Galvanized steel
Clamp Nickel-plated copper alloy
Terminal Tin-plated copper alloy
SCIP Number 96f29ec3-253d-47ee-b2d5-5085cc48fe55

COLOURS

Standard

On request



POLES **NAME** **3D FILE**

1	MV461-12,7-IT	File not available for this product
2	MV462-12,7-IT	File not available for this product