

MPT610-O

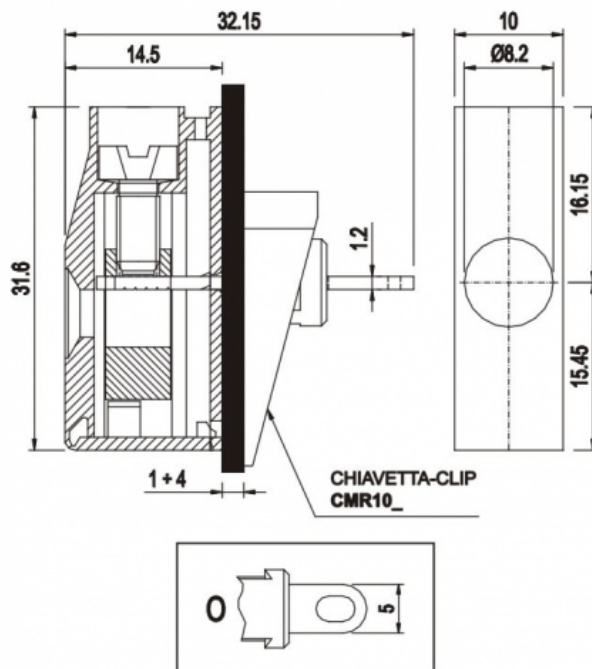

GENERAL INFORMATION

pitch	10 mm
Height	31.6 mm
Depth	14.5 mm
Dimensional class	Alta
Wire section	6.0 mm ² / 10 AWG
Clamp opening size	-
Wire stripping	max 13.5 mm
Operating temperature	-40 ÷ +130 °C

ELECTRICAL CHARACTERISTICS

Current	41 A
Voltage	450 V

MECHANICAL CHARACTERISTICS

Screw	M4
Recommended torque	1.2÷1.32 Nm / 10.8÷11.9 in.lbs

APPROVALS DATA



	EN 60998-1	EN 60998-1	UL 1059
Current	41 A	41 A	50 A factory / 50 A field
Voltage	450 V	450 V	600 V
Wire section	6.0 mm ²	6.0 mm ²	8 AWG
Torque	1.2 Nm	1.2 Nm	15.8 Lb-in
FILE	CA02.01615	40014733	E178356

MATERIALS

Housing	PA - UL 94 V0
Screw	Galvanized steel
Clamp	Nickel-plated copper alloy
Terminal	Tin-plated copper alloy

COLOURS

Standard

On request

