

# MPT1010-D-EZ

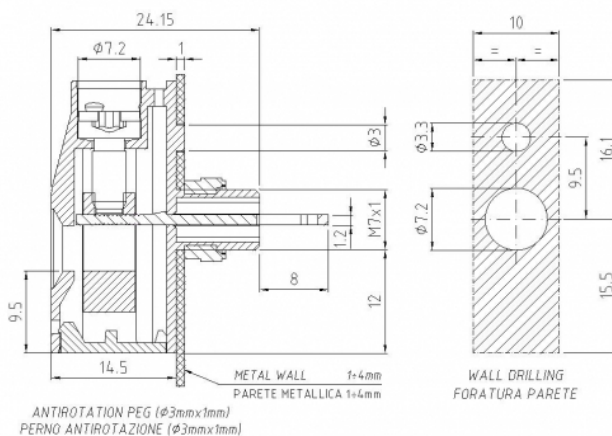

## GENERAL INFORMATION

pitch	10 mm
Height	31.6 mm
Depth	14.5 mm
Dimensional class	n/a
Wire section	10 mm <sup>2</sup> / 6 AWG
Clamp opening size	5.3 x 5.3 mm
Wire stripping	max 13.5 mm
Operating temperature	-40 ÷ +130 °C

## ELECTRICAL CHARACTERISTICS

Current	57 A
Voltage	450 V

## MECHANICAL CHARACTERISTICS

Screw	M4
Recommended torque	1.2÷1.32 Nm / 10.8÷11.9 in.lbs

## APPROVALS DATA



		EN 60998-1	UL 1059
Current	-	57 A	65 A factory / 65 A field
Voltage	-	450 V	600 V
Wire section	-	10,0 mm <sup>2</sup>	6÷30 AWG
Torque	-	1,2 Nm	15,8 Lb-in
FILE	-	40014733	E178356

## MATERIALS

Housing	PA - UL 94 V0
Screw	Galvanized steel
Clamp	Nickel-plated copper alloy
Terminal	Tin-plated copper alloy

## COLOURS

Standard



On request

