

# ML252-10-D-P

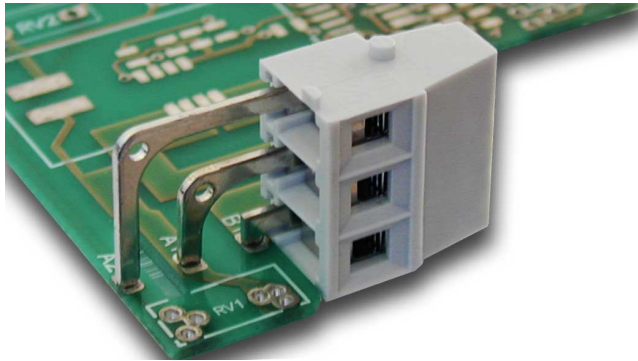

### GENERAL INFORMATION

pitch	10 mm
Height	15.3 mm
Depth	9.5 mm
Dimensional class	Media
Wire section	2.5 mm <sup>2</sup> / 14 AWG
Clamp opening size	2.7 x 2.7 mm
Wire stripping	max 7 mm
Operating temperature	-40 ÷ +130 °C

### ELECTRICAL CHARACTERISTICS

Current	16 A
Voltage	750 V
	-

### MECHANICAL CHARACTERISTICS

Screw	M3
Recommended torque	0.5÷0.55 Nm / 4.5÷4.9 in.lbs

### APPROVALS DATA



	<b>EN 60998-1</b>		<b>UL 1059</b>
Current	16 A	-	15 A factory / 15 A field
Voltage	750 V	-	300 V
Wire section	2.5 mm <sup>2</sup>	-	14 AWG
Torque	0.5 Nm	-	4.5 Lb-in
FILE	CA02.01614	-	E178356

### MATERIALS

Housing	PA - UL 94 V0
Screw	Galvanized steel
Clamp	Nickel-plated copper alloy
Terminal	Tin-plated copper alloy

### COLOURS



On request



<b>POLES</b>	<b>NAME</b>	<b>3D FILE</b>
2	ML252-10-D-P	File available

