

CODU

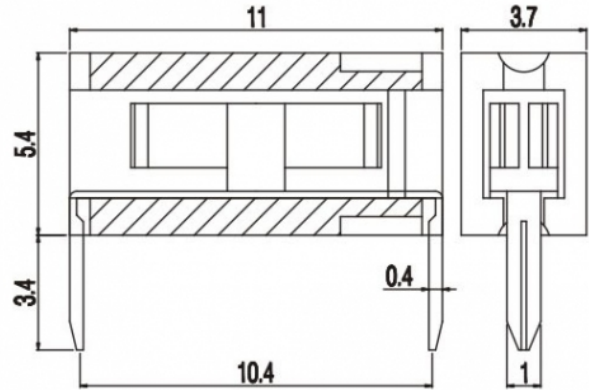

GENERAL INFORMATION

pitch	-
Height	5.4 mm
Depth	3.7 mm
Dimensional class	n/a
Wire section	-
Clamp opening size	-
Wire stripping	-
Operating temperature	-40 ÷ +130 °C

ELECTRICAL CHARACTERISTICS

Current	10 A
Voltage	450 V
Test Voltage	- kVrms/60s

MECHANICAL CHARACTERISTICS

Screw	-
Recommended torque	-

APPROVALS DATA



	EN 61984		
Current	10 A	-	-
Voltage	450 V	-	-
Wire section	-	-	-
Torque	-	-	-
FILE	EQ204	-	-

MATERIALS

Housing	PA - UL 94 V0
Screw	-
Clamp	-
Terminal	Tin-plated copper alloy

COLOURS

Standard

GN

On request

GY

BK

BL

RD

YL

OG