

CMR102

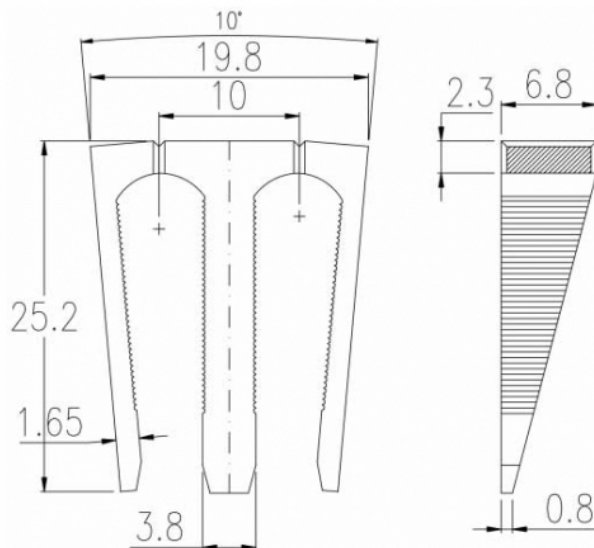

GENERAL INFORMATION

pitch	10 mm
Height	-
Depth	-
Dimensional class	n/a
Wire section	-
Clamp opening size	-
Wire stripping	-
Operating temperature	-

ELECTRICAL CHARACTERISTICS

Current	-
Voltage	-
Test Voltage	-

MECHANICAL CHARACTERISTICS

Screw	-
Recommended torque	-

APPROVALS DATA



Current	-	-	-
Voltage	-	-	-
Wire section	-	-	-
Torque	-	-	-
FILE	-	-	-

MATERIALS

Housing	PA - UL 94 V0
Screw	-
Clamp	-

Terminal

COLOURS

Standard



On request



POLES

01

NAME

CMR102

3D FILE

File available