

# SHS\_\_-10

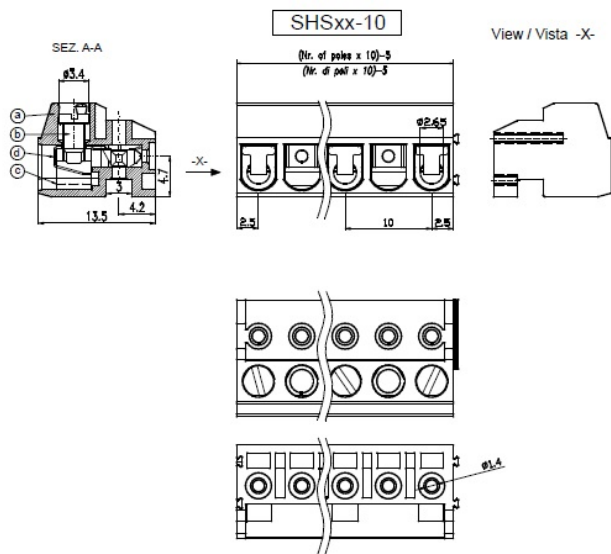

### GENERAL INFORMATION

pitch	10 mm
Height	10.8 mm
Depth	13.5 mm
Dimensional class	Media
Wire section	1.5 mm <sup>2</sup> / 16 AWG
Clamp opening size	-
Wire stripping	max 6 mm
Operating temperature	-40 ÷ +130 °C

### ELECTRICAL CHARACTERISTICS

Current	10 A
Voltage	630 V
impulse voltage	6 kV

### MECHANICAL CHARACTERISTICS

Screw	M2.5
Recommended torque	0.4÷4.4 Nm / 3.6÷3.9 in.lbs

### APPROVALS DATA



		EN 61984	UL 1059
Current	-	12 A	10 A factory / 10 A field
Voltage	-	500 V	300 V
Wire section	-	0.2÷2.5 mm <sup>2</sup>	16 AWG
Torque	-	0.4 Nm	3.5 Lb-in
FILE	-	40053107	E178356

### MATERIALS

Housing	PA - UL 94 V0
Screw	Galvanized steel
Clamp	Nickel-plated copper alloy
Terminal	Copper alloy
SCIP Number	f59fce50-2030-4a8c-a1d5-32dbe6d47a1f

**COLOURS**

Standard



On request



**POLES**

**NAME**

**3D FILE**

01	SHS01-10	File available
02	SHS02-10	File available
03	SHS03-10	File not available for this product
04	SHS04-10	File not available for this product
05	SHS05-10	File not available for this product
06	SHS06-10	File not available for this product