

PI__-5,08-IQ

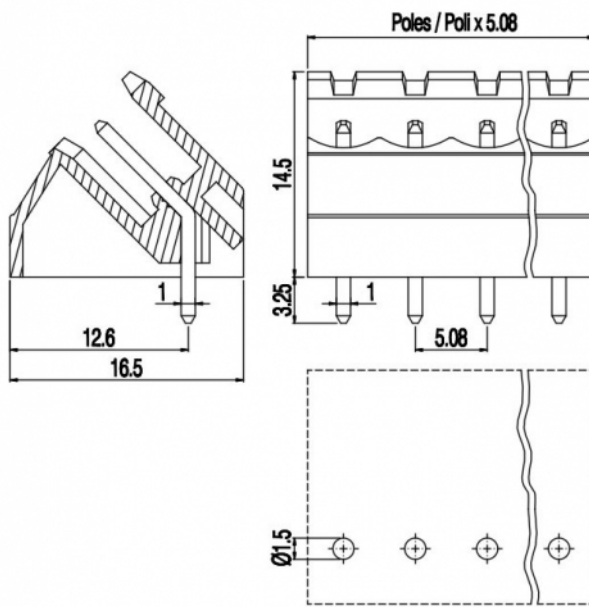

GENERAL INFORMATION

pitch	5,08 mm
Height	14.5 mm
Depth	16.5 mm
Dimensional class	Media
Wire section	-
Clamp opening size	-
Wire stripping	-
Operating temperature	-40 ÷ +130 °C

ELECTRICAL CHARACTERISTICS

Current	12 A
Voltage	250 V
impulse voltage	4 kV

MECHANICAL CHARACTERISTICS

Screw	-
Recommended torque	-

APPROVALS DATA



	EN 61984		UL 1059
Current	12 A	-	12 A factory / 12 A field
Voltage	250 V	-	300 V
Wire section	-	-	-
Torque	-	-	-
FILE	CA02.04178	-	E178356

MATERIALS

Housing	PA - UL 94 V0
Screw	-
Clamp	-

Terminal

Tin-plated copper alloy

COLOURS

Standard

On request



POLES	NAME	3D FILE
02	PI02-5,08-IQ	File not available for this product
03	PI03-5,08-IQ	File not available for this product
04	PI04-5,08-IQ	File not available for this product
05	PI05-5,08-IQ	File not available for this product
06	PI06-5,08-IQ	File not available for this product
07	PI07-5,08-IQ	File not available for this product
08	PI08-5,08-IQ	File not available for this product
09	PI09-5,08-IQ	File not available for this product
10	PI10-5,08-IQ	File not available for this product
11	PI11-5,08-IQ	File not available for this product
12	PI12-5,08-IQ	File not available for this product
13	PI13-5,08-IQ	File not available for this product
14	PI14-5,08-IQ	File not available for this product
15	PI15-5,08-IQ	File not available for this product
16	PI16-5,08-IQ	File not available for this product
17	PI17-5,08-IQ	File not available for this product
18	PI18-5,08-IQ	File not available for this product
19	PI19-5,08-IQ	File not available for this product
20	PI20-5,08-IQ	File not available for this product
21	PI21-5,08-IQ	File not available for this product
22	PI22-5,08-IQ	File not available for this product
23	PI23-5,08-IQ	File not available for this product
24	PI24-5,08-IQ	File not available for this product