

# PF\_\_-5-H-M

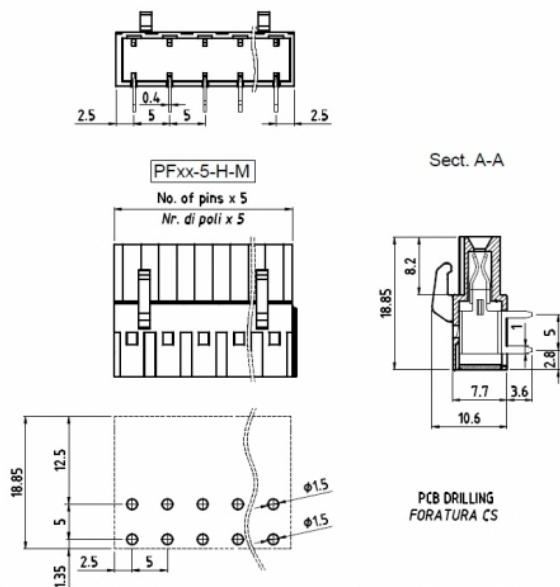
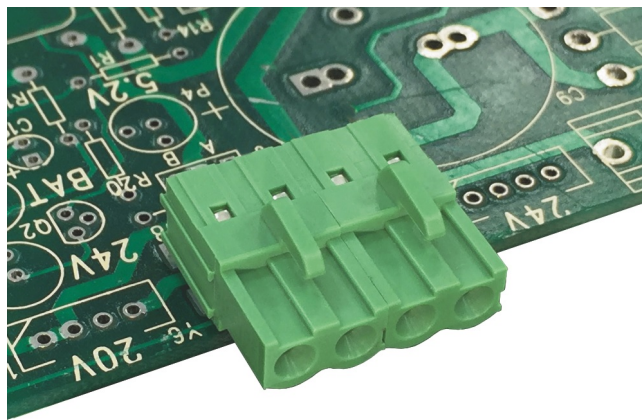

## GENERAL INFORMATION

pitch	5 mm
Height	7.7 mm
Depth	18.85 mm
Dimensional class	Media
Wire section	-
Clamp opening size	-
Wire stripping	-
Operating temperature	-40 ÷ +130 °C

## ELECTRICAL CHARACTERISTICS

Current	15 A
Voltage	250 V
impulse voltage	4 kV

## MECHANICAL CHARACTERISTICS

Screw	-
Recommended torque	-

## APPROVALS DATA



Current	-	-	<b>UL 1059</b>
Voltage	-	-	22 A factory / 20 A field
Wire section	-	-	300 V
Torque	-	-	-
FILE	-	-	E178356

## MATERIALS

Housing	PA - UL 94 V0
Screw	-
Clamp	-
Terminal	Tin-plated copper alloy

**COLOURS**

Standard



On request



POLES	NAME	3D FILE
02	PF02-5-H-M	File not available for this product
03	PF03-5-H-M	File not available for this product
04	PF04-5-H-M	File not available for this product
05	PF05-5-H-M	File not available for this product
06	PF06-5-H-M	File not available for this product
07	PF07-5-H-M	File not available for this product
08	PF08-5-H-M	File not available for this product
09	PF09-5-H-M	File not available for this product
10	PF10-5-H-M	File not available for this product
11	PF11-5-H-M	File not available for this product
12	PF12-5-H-M	File not available for this product