

# PF\_\_-5,08-H-M

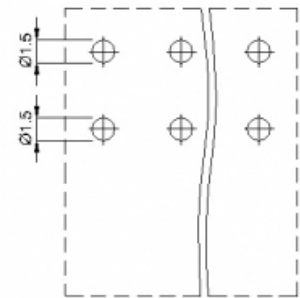
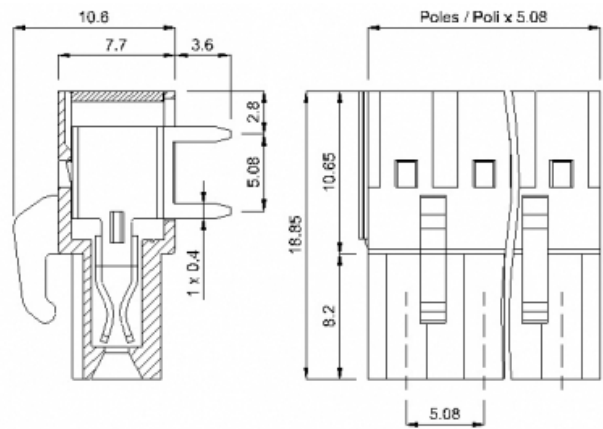
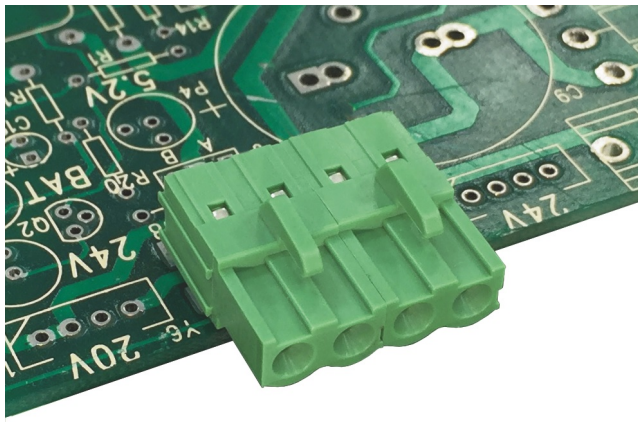

## GENERAL INFORMATION

pitch	5,08 mm
Height	7.7 mm
Depth	18.85 mm
Dimensional class	Media
Wire section	-
Clamp opening size	-
Wire stripping	-
Operating temperature	-40 ÷ +105 °C

## ELECTRICAL CHARACTERISTICS

Current	16 A
Voltage	250 V
impulse voltage	4 kV

## MECHANICAL CHARACTERISTICS

Screw	-
Recommended torque	-

## APPROVALS DATA



Current	-	-	UL 1059
Voltage	-	-	22 A factory / 20 A field
Wire section	-	-	300 V
Torque	-	-	-

FILE - - E178356

**MATERIALS**

Housing PA - UL 94 V0  
 Screw -  
 Clamp -  
 Terminal Tin-plated copper alloy

**COLOURS**

Standard



On request



**POLES**

**NAME**

**3D FILE**

02	PF02-5,08-H-M	File available
03	PF03-5,08-H-M	File available
04	PF04-5,08-H-M	File not available for this product
05	PF05-5,08-H-M	File not available for this product
06	PF06-5,08-H-M	File not available for this product
07	PF07-5,08-H-M	File not available for this product
08	PF08-5,08-H-M	File not available for this product
09	PF09-5,08-H-M	File not available for this product
10	PF10-5,08-H-M	File not available for this product
11	PF11-5,08-H-M	File not available for this product
12	PF12-5,08-H-M	File not available for this product