

# PDV\_\_-3,5-H-M

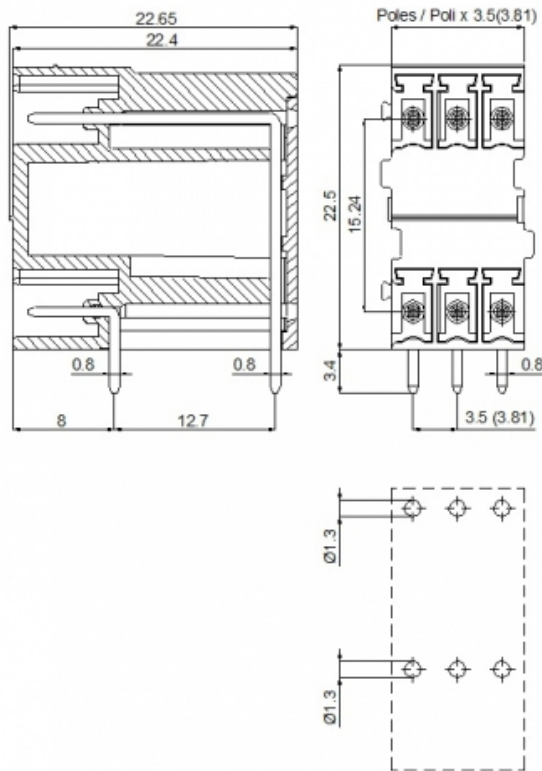
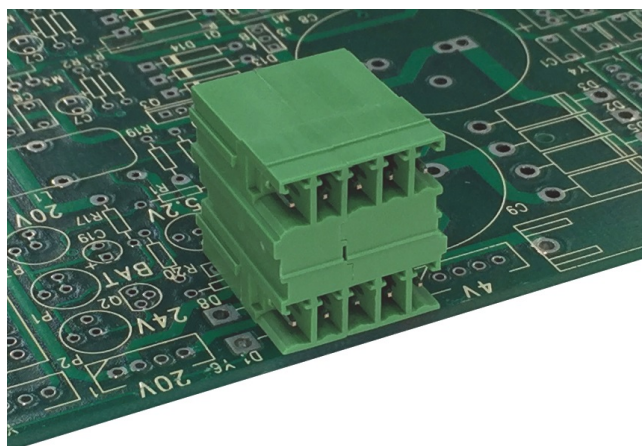

## GENERAL INFORMATION

pitch	3,5 mm
Height	22.65 mm
Depth	22.5 mm
Dimensional class	Media
Wire section	-
Clamp opening size	-
Wire stripping	-
Operating temperature	-40 ÷ +130 °C

## ELECTRICAL CHARACTERISTICS

Current	11 A
Voltage	160 V
impulse voltage	2.5 kV

## MECHANICAL CHARACTERISTICS

Screw	-
Recommended torque	-

## APPROVALS DATA



		<b>EN 61984</b>	<b>UL 1059</b>
Current	-	8 A	11 A factory / 11 A field
Voltage	-	160 V	300 V
Wire section	-	-	-

Torque - - -  
 FILE - 40048261 E178356

**MATERIALS**

Housing PA - UL 94 V0  
 Screw -  
 Clamp -  
 Terminal Tin-plated copper alloy

**COLOURS**

Standard



On request



**POLES**

**NAME**

**3D FILE**

POLES	NAME	3D FILE
02	PDV02-3,5-H-M	File available
03	PDV03-3,5-H-M	File available