

MVSP27_-7,62-V

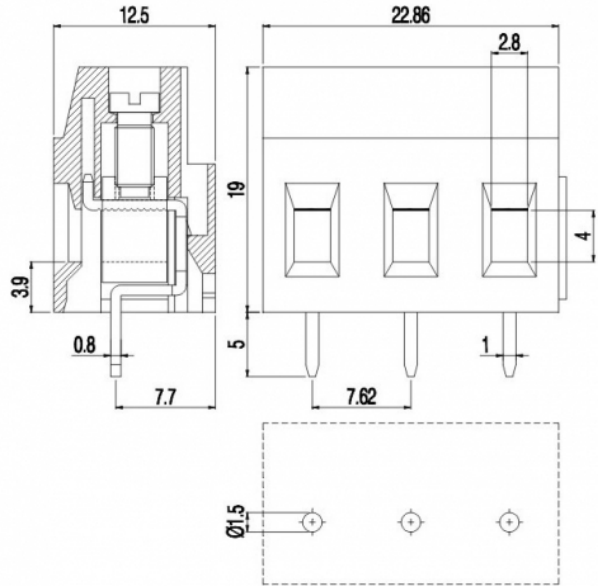

GENERAL INFORMATION

pitch	7,62 mm
Height	19 mm
Depth	12.5 mm
Dimensional class	Media
Wire section	2.5 mm ² / 14 AWG
Clamp opening size	2.8 x 4 mm
Wire stripping	max 9.5 mm
Operating temperature	-40 ÷ +130 °C

ELECTRICAL CHARACTERISTICS

Current	24 A
Voltage	750 V
impulse voltage	3 kV

MECHANICAL CHARACTERISTICS

Screw	M3
Recommended torque	0.8÷0.88 Nm / 7.2÷7.9 in.lbs

APPROVALS DATA



	EN 60998-1		UL 1059
Current	24 A	-	20 A factory / 15 A field
Voltage	750 V	-	300 V
Wire section	2.5 mm ²	-	14 AWG
Torque	0.8 Nm	-	4.5 Lb-in
FILE	CA02.00599	-	E178356

MATERIALS

Housing	PA - UL 94 V0
Screw	Galvanized steel

Clamp
Terminal
SCIP Number

Nickel-plated copper alloy
Tin-plated copper alloy
97a4c75c-d640-453d-b7b0-7dc991b80e95

COLOURS



On request



POLES

NAME

3D FILE

2	MVSP272-7,62-V	File not available for this product
3	MVSP273-7,62-V	File not available for this product