

# MVSP25\_-10,16-H

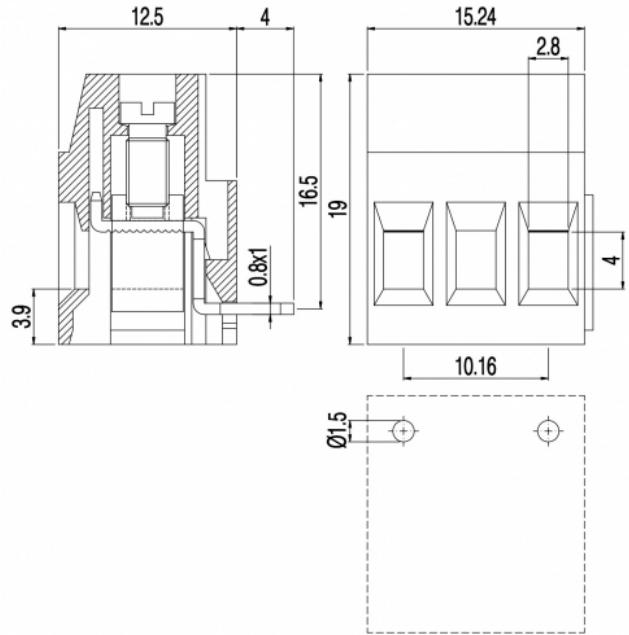

### GENERAL INFORMATION

pitch	10,16 mm
Height	19 mm
Depth	12.5 mm
Dimensional class	Media
Wire section	2.5 mm <sup>2</sup> / 14 AWG
Clamp opening size	2.8 x 4 mm
Wire stripping	max 9.5 mm
Operating temperature	-40 ÷ +130 °C

### ELECTRICAL CHARACTERISTICS

Current	24 A
Voltage	750 V
impulse voltage	3 kV

### MECHANICAL CHARACTERISTICS

Screw	M3
Recommended torque	0.8÷0.88 Nm / 7.2÷7.9 in.lbs

### APPROVALS DATA



	<b>EN 60998-1</b>		<b>UL 1059</b>
Current	24 A	-	18 A factory / 15 A field
Voltage	750 V	-	300 V
Wire section	2.5 mm <sup>2</sup>	-	14 AWG
Torque	0.8 Nm	-	4.5 Lb-in
FILE	CA02.00599	-	E178356

### MATERIALS

Housing	PA - UL 94 V0
---------	---------------

Screw	Galvanized steel
Clamp	Nickel-plated copper alloy
Terminal	Tin-plated copper alloy
SCIP Number	4857c4e6-479f-4765-acd0-7361f5cc6333

**COLOURS**

Standard



On request



POLES	NAME	3D FILE
1	MVSP251-10,16-H	File not available for this product
2	MVSP252-10,16-H	File not available for this product