

MVS13_-7-H-L

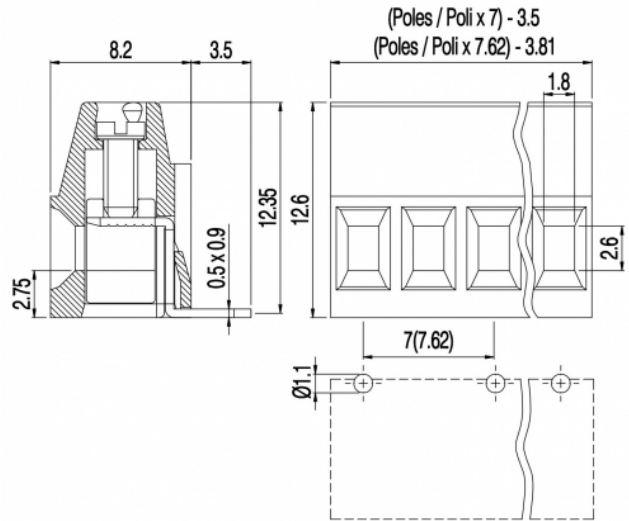
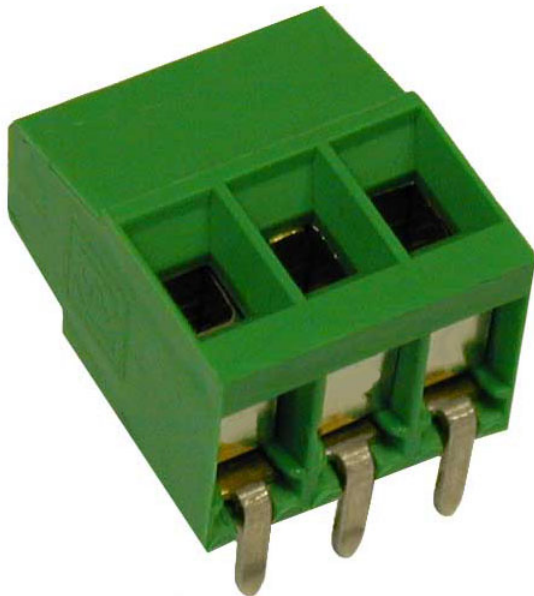

GENERAL INFORMATION

pitch	7 mm
Height	12.6 mm
Depth	8.2 mm
Dimensional class	Bassa
Wire section	1.5 mm ² / 16 AWG
Clamp opening size	1.8 x 2.6 mm
Wire stripping	max 6 mm
Operating temperature	-40 ÷ +130 °C

ELECTRICAL CHARACTERISTICS

Current	13,5 A
Voltage	450 V
impulse voltage	2.5 kV

MECHANICAL CHARACTERISTICS

Screw	M2
Recommended torque	0.2÷0.22 Nm / 1.8÷2 in.lbs

APPROVALS DATA



	EN 60998-1		UL 1059
Current	17.5 A	-	12 A factory / 10 A field
Voltage	450 V	-	300 V
Wire section	1.5 mm ²	-	16 AWG
Torque	0.2 Nm	-	1.8 Lb-in
FILE	CA02.04718	-	E178356

MATERIALS

Housing	PA - UL 94 V0
Screw	Galvanized steel

Clamp
Terminal
SCIP Number

Tin-plated copper alloy
Tin-plated copper alloy
44bdd228-db28-48a8-9c38-13f7c55006ec

COLOURS

Standard



On request



POLES

NAME

3D FILE

2	MVS132-7-H-L	File not available for this product
3	MVS133-7-H-L	File not available for this product
4	MVS134-7-H-L	File not available for this product
5	MVS135-7-H-L	File not available for this product
6	MVS136-7-H-L	File not available for this product