

# MV46\_-12,7-H

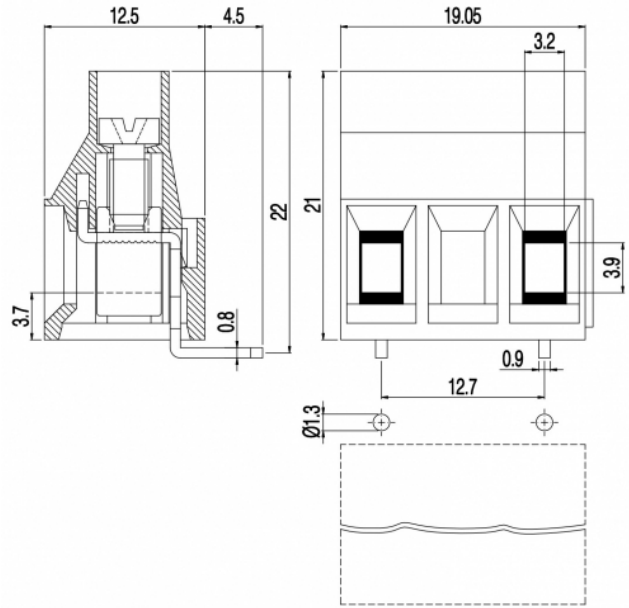

### GENERAL INFORMATION

pitch	12,7 mm
Height	21 mm
Depth	12.5 mm
Dimensional class	Alta
Wire section	6.0 mm <sup>2</sup> / 10 AWG
Clamp opening size	3.2 x 3.9 mm
Wire stripping	max 9 mm
Operating temperature	-40 ÷ +130 °C

### ELECTRICAL CHARACTERISTICS

Current	32 A
Voltage	750 V
impulse voltage	3 kV

### MECHANICAL CHARACTERISTICS

Screw	M3
Recommended torque	0.8÷0.88 Nm / 7.2÷7.9 in.lbs

### APPROVALS DATA



	EN 60998-1	EN 60998-1	UL 1059
Current	32 A	25 A	30 A factory / 30 A field
Voltage	750 V	750 V	600 V
Wire section	6.0 mm <sup>2</sup>	4.0 mm <sup>2</sup>	10 AWG
Torque	0.8 Nm	0.5 Nm	7.2 Lb-in
FILE	EP150	40014734	E178356

### MATERIALS

Housing	PA - UL 94 V0
Screw	Galvanized steel
Clamp	Nickel-plated copper alloy

Terminal  
SCIP Number

Tin-plated copper alloy  
96f29ec3-253d-47ee-b2d5-5085cc48fe55

**COLOURS**

Standard

On request



**POLES**

**NAME**

**3D FILE**

1	MV461-12,7-H	File not available for this product
2	MV462-12,7-H	File not available for this product