

# MV27D\_-7,5-V

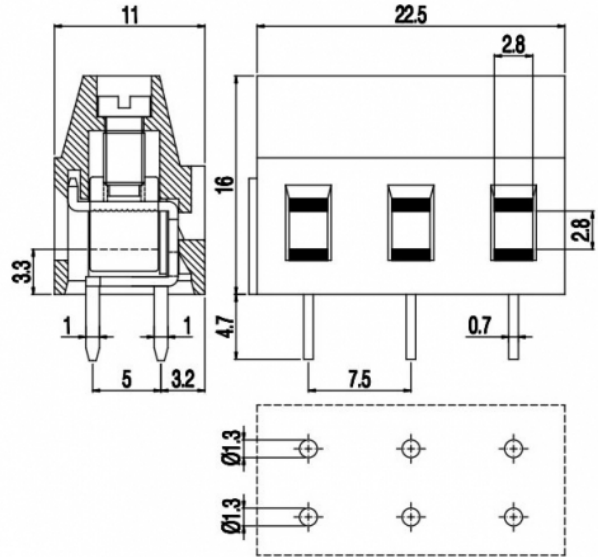
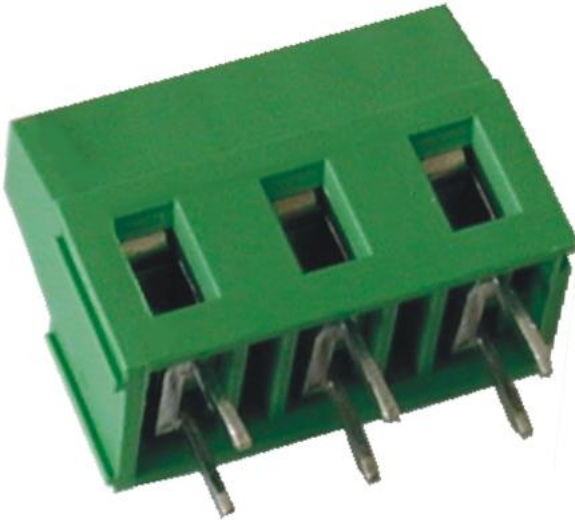

### GENERAL INFORMATION

pitch	7,5 mm
Height	16 mm
Depth	11 mm
Dimensional class	Media
Wire section	2.5 mm <sup>2</sup> / 14 AWG
Clamp opening size	2.8 x 2.8 mm
Wire stripping	max 8 mm
Operating temperature	-40 ÷ +130 °C

### ELECTRICAL CHARACTERISTICS

Current	24 A
Voltage	750 V
impulse voltage	3 kV

### MECHANICAL CHARACTERISTICS

Screw	M3
Recommended torque	0.8÷0.88 Nm / 7.2÷7.9 in.lbs

### APPROVALS DATA



	<b>EN 60998-1</b>		<b>UL 1059</b>
Current	24 A	-	20 A factory / 15 A field
Voltage	750 V	-	300 V
Wire section	2.5 mm <sup>2</sup>	-	14 AWG
Torque	0.8 Nm	-	4.5 Lb-in
FILE	CA02.00599	-	E178356

### MATERIALS

Housing	PA - UL 94 V0
Screw	Galvanized steel
Clamp	Nickel-plated copper alloy
Terminal	Tin-plated copper alloy

SCIP Number

37ed019f-0bc4-4fba-ad8e-2af8b69b1648

**COLOURS**

Standard



On request



**POLES**

**NAME**

**3D FILE**

2  
3

MV27D2-7,5-V  
MV27D3-7,5-V

File not available for this product  
File not available for this product