

MV27_-7,5-V

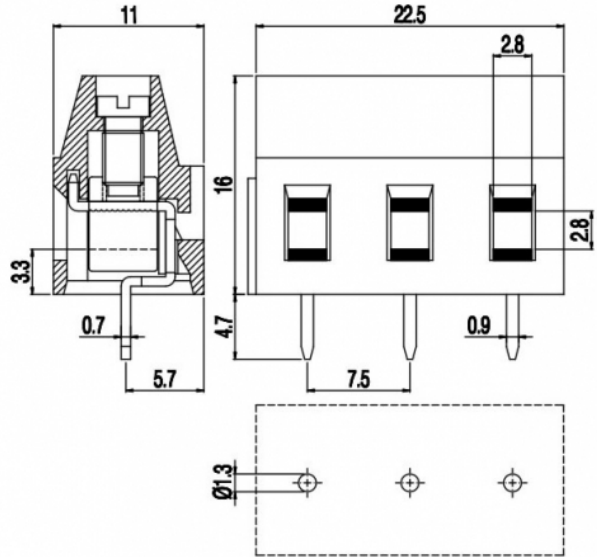
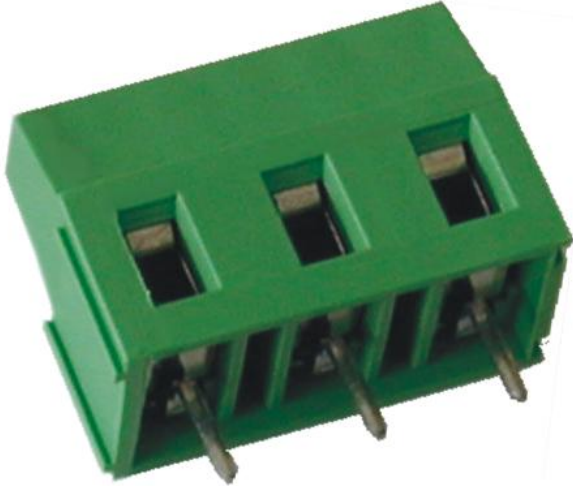

GENERAL INFORMATION

pitch	7,5 mm
Height	16 mm
Depth	11 mm
Dimensional class	Media
Wire section	2.5 mm ² / 14 AWG
Clamp opening size	2.8 x 2.8 mm
Wire stripping	max 8 mm
Operating temperature	-40 ÷ +130 °C

ELECTRICAL CHARACTERISTICS

Current	16 A
Voltage	750 V
impulse voltage	3 kV

MECHANICAL CHARACTERISTICS

Screw	M3
Recommended torque	0.5÷0.55 Nm / 4.5÷4.9 in.lbs

APPROVALS DATA



	EN 60998-1	EN 60998-1	UL 1059
Current	16 A	16 A	16 A factory / 15 A field
Voltage	750 V	750 V	300 V
Wire section	2.5 mm ²	2.5 mm ²	14 AWG
Torque	0.5 Nm	0.5 Nm	4.5 Lb-in
FILE	EP149	40023956	E178356

MATERIALS

Housing	PA - UL 94 V0
Screw	Galvanized steel
Clamp	Nickel-plated copper alloy
Terminal	Tin-plated copper alloy

SCIP Number

5f030aac-dc47-4381-afcc-ec8e4be57bf7

COLOURS

Standard



On request



POLES

NAME

3D FILE

2
3

MV272-7,5-V
MV273-7,5-V

File available
File available