

MV15_-10,16-V-L

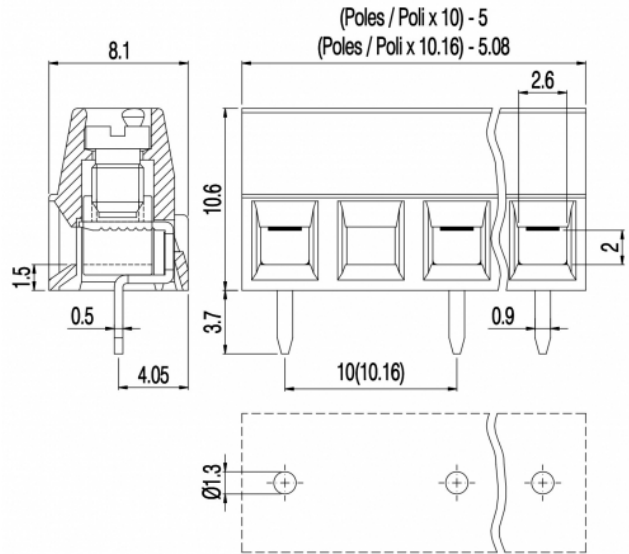
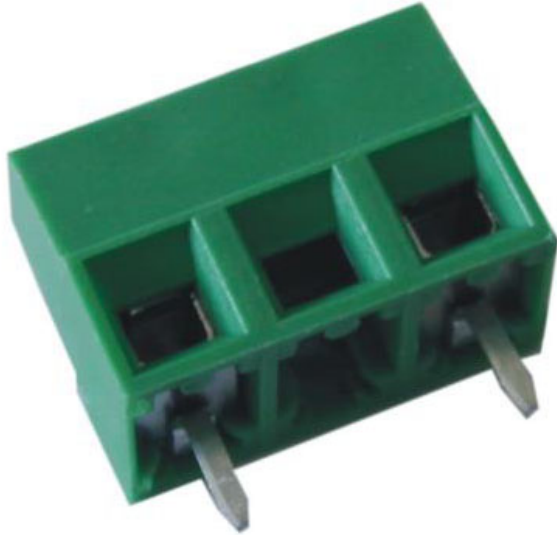

GENERAL INFORMATION

pitch	10,16 mm
Height	10.6 mm
Depth	8.1 mm
Dimensional class	Bassa
Wire section	1.5 mm ² / 16 AWG
Clamp opening size	2.6 x 2 mm
Wire stripping	max 6 mm
Operating temperature	-40 ÷ +130 °C

ELECTRICAL CHARACTERISTICS

Current	13.5 A
Voltage	750 V
impulse voltage	2 kV

MECHANICAL CHARACTERISTICS

Screw	M3
Recommended torque	0.5±0.55 Nm / 4.5÷4.9 in.lbs

APPROVALS DATA



	EN 60998-1		UL 1059
Current	13.5 A	-	13.5 A factory / 10 A field
Voltage	750 V	-	600 V
Wire section	1.5 mm ²	-	16 AWG
Torque	0.5 Nm	-	4.5 Lb-in
FILE	EQ202	-	E178356

MATERIALS

Housing	PA - UL 94 V0
Screw	Galvanized steel
Clamp	Nickel-plated copper alloy
Terminal	Tin-plated copper alloy

SCIP Number

8e28a064-07ab-45c1-afc0-7873209ceda4

COLOURS

Standard

On request



POLES	NAME	3D FILE
2	MV152-10,16-V-L	File not available for this product
3	MV153-10,16-V-L	File not available for this product
4	MV154-10,16-V-L	File not available for this product
5	MV155-10,16-V-L	File not available for this product
6	MV156-10,16-V-L	File not available for this product