

MV13_-7-H-L

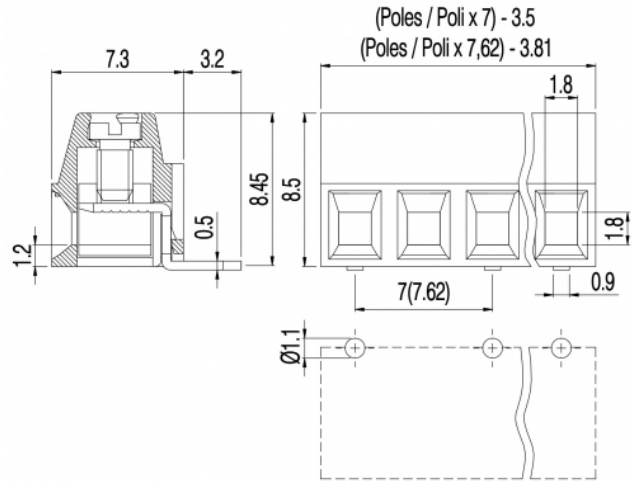
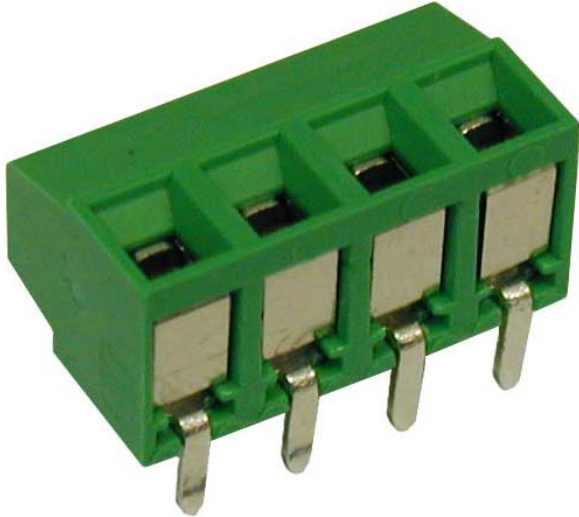

GENERAL INFORMATION

pitch	7 mm
Height	8.5 mm
Depth	7.3 mm
Dimensional class	Bassa
Wire section	1.0 mm ² / 16 AWG
Clamp opening size	1.8 x 1.8 mm
Wire stripping	max 6 mm
Operating temperature	-40 ÷ +130 °C

ELECTRICAL CHARACTERISTICS

Current	17,5 A
Voltage	450 V
impulse voltage	2.5 kV

MECHANICAL CHARACTERISTICS

Screw	M2
Recommended torque	0.2÷0.22 Nm / 1.8÷2 in.lbs

APPROVALS DATA



	EN 60998-1		UL 1059
Current	13.5 A	-	12 A factory / 10 A field
Voltage	450 V	-	300 V
Wire section	1.0 mm ²	-	16 AWG
Torque	0.2 Nm	-	1.8 Lb-in
FILE	CA02.04718	-	E178356

MATERIALS

Housing	PA - UL 94 V0
Screw	Galvanized steel
Clamp	Tin-plated copper alloy
Terminal	Tin-plated copper alloy

COLOURS

Standard



On request



POLES	NAME	3D FILE
2	MV132-7-H-L	File not available for this product
3	MV133-7-H-L	File not available for this product
4	MV134-7-H-L	File not available for this product
5	MV135-7-H-L	File not available for this product
6	MV136-7-H-L	File not available for this product