

MV10_-20,32-V

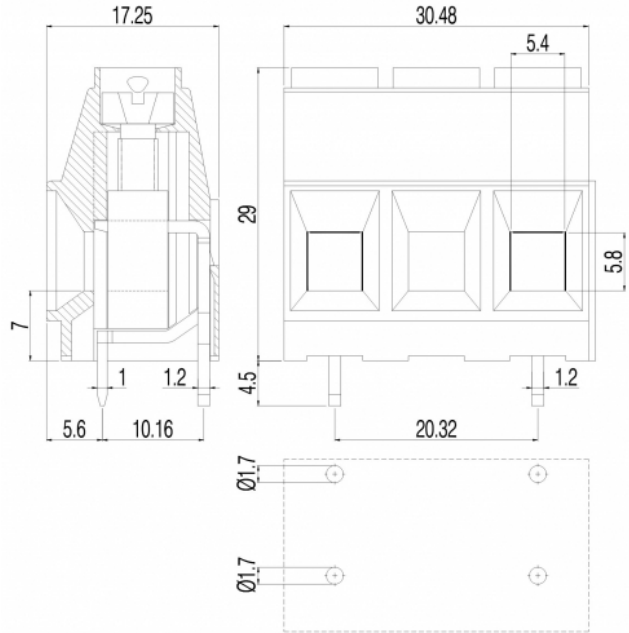

GENERAL INFORMATION

pitch	20,32 mm
Height	29.3 mm
Depth	17.25 mm
Dimensional class	Alta
Wire section	10 mm ² / 8 AWG
Clamp opening size	5.4 x 5.8 mm
Wire stripping	max 15 mm
Operating temperature	-40 ÷ +130 °C

ELECTRICAL CHARACTERISTICS

Current	57 A
Voltage	750 V
impulse voltage	3 kV

MECHANICAL CHARACTERISTICS

Screw	M4
Recommended torque	1.2÷1.5 Nm / 10.8÷13.6 in.lbs

APPROVALS DATA



		EN 60998-1	UL 1059
Current	-	70 A	57 A factory / 57 A field
Voltage	-	1000 V	600 V
Wire section	-	16 mm ²	6 AWG
Torque	-	1.5 Nm	10.8 Lb-in
FILE	-	40034945	E178356

MATERIALS

Housing	PA - UL 94 V0
Screw	Galvanized steel
Clamp	Nickel-plated copper alloy

Terminal
SCIP Number

Tin-plated copper alloy
0e22b4d0-f741-437c-bf88-e67efc1bf4a7

COLOURS

Standard



On request



POLES

NAME

3D FILE

1
2

MV101-20,32-V
MV102-20,32-V

File not available for this product
File not available for this product