

# MV10\_-12,7-V-A

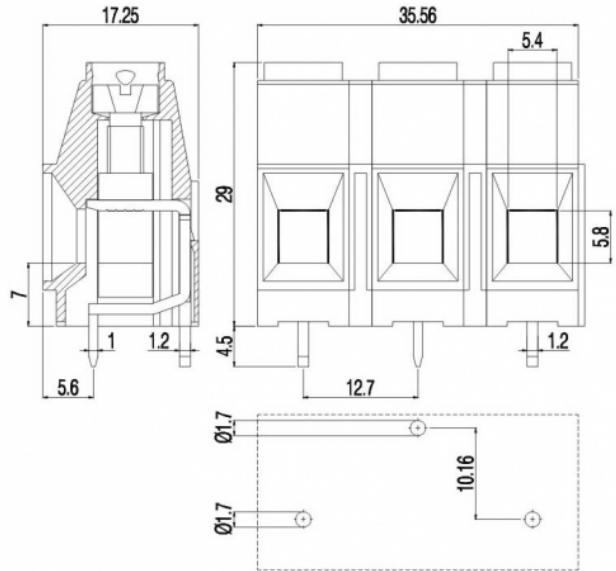
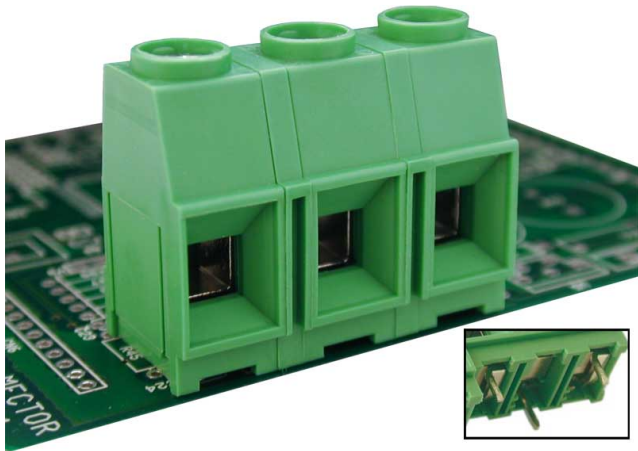

### GENERAL INFORMATION

pitch	12,7 mm
Height	29 mm
Depth	17.25 mm
Dimensional class	Alta
Wire section	10 mm <sup>2</sup> / 8 AWG
Clamp opening size	5.4 x 5.8 mm
Wire stripping	max 15 mm
Operating temperature	-40 ÷ +130 °C

### ELECTRICAL CHARACTERISTICS

Current	42 A
Voltage	1000 V
impulse voltage	3,5 kV

### MECHANICAL CHARACTERISTICS

Screw	M4
Recommended torque	1.2÷1.5 Nm / 10.8÷13.6 in.lbs

### APPROVALS DATA



### EN 60998-1

Current	-	49 A	-
Voltage	-	1000 V	-
Wire section	-	16 mm <sup>2</sup>	-
Torque	-	1.5 Nm	-
FILE	-	40034945	-

### MATERIALS

Housing	PA - UL 94 V0
Screw	Galvanized steel
Clamp	Nickel-plated copper alloy
Terminal	Tin-plated copper alloy

SCIP Number

0e22b4d0-f741-437c-bf88-e67efc1bf4a7

**COLOURS**

Standard



On request



**POLES**

1

**NAME**

MV101-12,7-V-A

**3D FILE**

File not available for this product