

# MT21\_-10

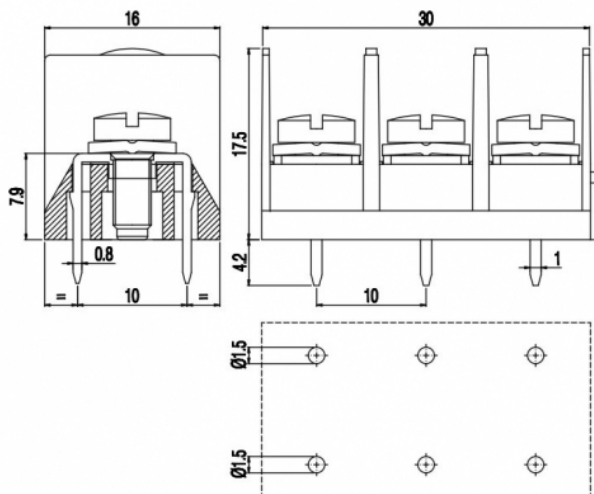

## GENERAL INFORMATION

pitch	10 mm
Height	17.5 mm
Depth	16 mm
Dimensional class	Media
Wire section	2x2.5 mm <sup>2</sup> / 2x14 AWG
Clamp opening size	-
Wire stripping	max 11 mm
Operating temperature	-40 ÷ +130 °C

## ELECTRICAL CHARACTERISTICS

Current	25 A
Voltage	750 V
impulse voltage	3 kV

## MECHANICAL CHARACTERISTICS

Screw	M3.5
Recommended torque	0.8÷0.88 Nm / 7.2÷7.9 in.lbs

## APPROVALS DATA



	EN 60998-1	EN 60998-1	UL 1059
Current	25 A	25 A	15 A factory / 20 A field
Voltage	750 V	750 V	600 V
Wire section	2x2.5 mm <sup>2</sup>	2x2.5 mm <sup>2</sup>	12 AWG
Torque	0.8 Nm	0.8 Nm	7.2 Lb-in
FILE	EQ203	40019721	E178356

## MATERIALS

Housing	PA - UL 94 V0
Screw	Galvanized steel

Clamp  
Terminal

-  
Tin-plated copper alloy

**COLOURS**

Standard

On request



**POLES**

**NAME**

**3D FILE**

2	MT212-10	File available
3	MT213-10	File not available for this product