

# MT17\_-15-WC

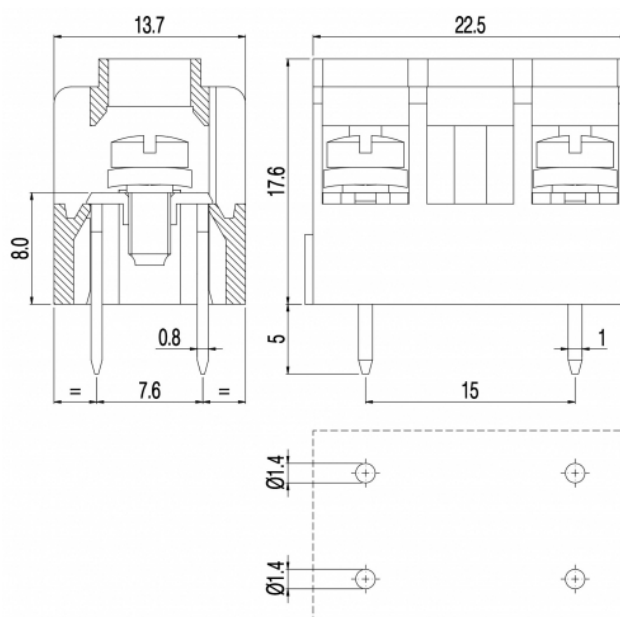

## GENERAL INFORMATION

pitch	15 mm
Height	17.6 mm
Depth	13.7 mm
Dimensional class	Media
Wire section	2x2.5 mm <sup>2</sup> / 2x14 AWG
Clamp opening size	-
Wire stripping	max 9 mm
Operating temperature	-40 ÷ +130 °C

## ELECTRICAL CHARACTERISTICS

Current	24 A
Voltage	750 V
Test Voltage	3 kVrms/60s

## MECHANICAL CHARACTERISTICS

Screw	M3
Recommended torque	0.5÷0.55 Nm / 4.5÷4.9 in.lbs

## APPROVALS DATA



Current	-	-	<b>UL 1059</b>
Voltage	-	-	20 A factory / 15 A field
Wire section	-	-	600 V
Torque	-	-	14 ÷ 30 AWG
FILE	-	-	4.5 Lb-in
			E178356

## MATERIALS

Housing	PA - UL 94 V0
Screw	Galvanized steel
Clamp	-

Terminal

Tin-plated copper alloy

**COLOURS**

Standard

On request



**POLES**

**NAME**

**3D FILE**

1	MT171-15-WC	File not available for this product
2	MT172-15-WC	File not available for this product