

# MPT610-D-E

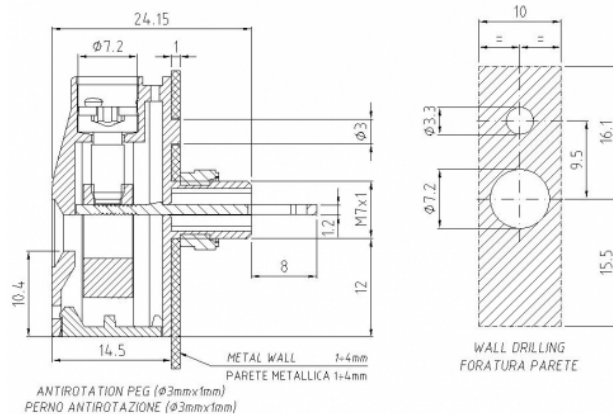

## GENERAL INFORMATION

pitch	10 mm
Height	31.6 mm
Depth	14.5 mm
Dimensional class	n/a
Wire section	6.0 mm <sup>2</sup> / 10 AWG
Clamp opening size	5.3 x 4.4 mm
Wire stripping	max 13.5 mm
Operating temperature	-40 ÷ +130 °C

## ELECTRICAL CHARACTERISTICS

Current	24 A
Voltage	450 V

## MECHANICAL CHARACTERISTICS

Screw	M4
Recommended torque	1.2 ÷ 1.32 Nm / 10.8 ÷ 11.9 in.lbs

## APPROVALS DATA



	EN 60998-1	EN 60998-1	UL 1059
Current	41 A	41 A	50 A factory / 50 A field
Voltage	450 V	450 V	600 V
Wire section	6,0 mm <sup>2</sup>	6,0 mm <sup>2</sup>	8 AWG
Torque	1,2 Nm	1,2 Nm	15,8 Lb-in
FILE	CA02.01615	40014733	E178356

## MATERIALS

Housing	PA - UL 94 V0
Screw	Galvanized steel
Clamp	Nickel-plated copper alloy
Terminal	Tin-plated copper alloy

## COLOURS

Standard



On request



