

MPT410-D

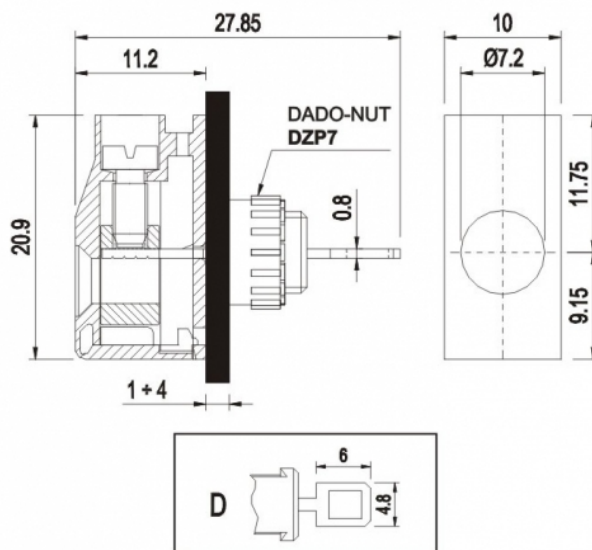

GENERAL INFORMATION

pitch	10 mm
Height	20.9 mm
Depth	11.2 mm
Dimensional class	Alta
Wire section	4.0 mm ² / 12 AWG
Clamp opening size	-
Wire stripping	max 10 mm
Operating temperature	-40 ÷ +130 °C

ELECTRICAL CHARACTERISTICS

Current	32 A
Voltage	450 V
Test Voltage	-

MECHANICAL CHARACTERISTICS

Screw	M3
Recommended torque	0.5÷0.55 Nm / 4.5÷4.9 in.lbs

APPROVALS DATA



	EN 60998-1	EN 60998-1	UL 1059
Current	32 A	32 A	36 A factory / 30 A field
Voltage	450 V	450 V	600 V
Wire section	4.0 mm ²	4.0 mm ²	10 ÷ 30 AWG
Torque	0.5 Nm	0.5 Nm	4.5 Lb-in
FILE	CA02.00601	40014733	E178356

MATERIALS

Housing	PA - UL 94 V0
Screw	Galvanized steel
Clamp	Nickel-plated copper alloy
Terminal	Tin-plated copper alloy

COLOURS

Standard

GN

On request

GY

BK

BL

RD

YL

OG