

# MPT410-D-E

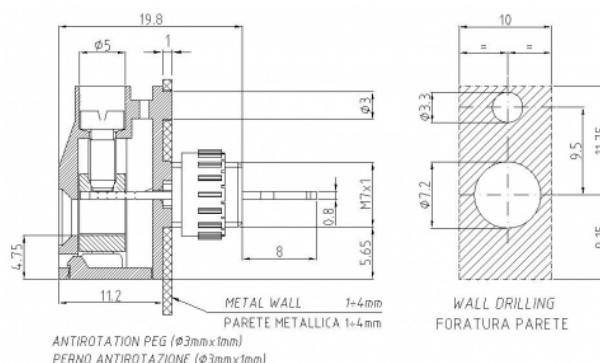

## GENERAL INFORMATION

|                       |                            |
|-----------------------|----------------------------|
| pitch                 | 10 mm                      |
| Height                | 20.9 mm                    |
| Depth                 | 11.2 mm                    |
| Dimensional class     | Alta                       |
| Wire section          | 4 mm <sup>2</sup> / 12 AWG |
| Clamp opening size    | 3.1 x 3.9 mm               |
| Wire stripping        | max 10 mm                  |
| Operating temperature | -40 ÷ +130 °C              |

## ELECTRICAL CHARACTERISTICS

|         |       |
|---------|-------|
| Current | 32 A  |
| Voltage | 450 V |

## MECHANICAL CHARACTERISTICS

|                    |                                  |
|--------------------|----------------------------------|
| Screw              | M3                               |
| Recommended torque | 0.5 ÷ 0.55 Nm / 4.5 ÷ 4.9 in.lbs |

## APPROVALS DATA



|              | EN 60998-1        | EN 60998-1        | UL 1059                   |
|--------------|-------------------|-------------------|---------------------------|
| Current      | 32 A              | 32 A              | 36 A factory / 30 A field |
| Voltage      | 450 V             | 450 V             | 600 V                     |
| Wire section | 4 mm <sup>2</sup> | 4 mm <sup>2</sup> | 10 AWG                    |
| Torque       | 0,5 Nm            | 0,5 Nm            | 4,5 Lb-in                 |
| FILE         | CA02.00601        | 40014733          | E178356                   |

## MATERIALS

|          |                            |
|----------|----------------------------|
| Housing  | PA - UL 94 V0              |
| Screw    | Galvanized steel           |
| Clamp    | Nickel-plated copper alloy |
| Terminal | Tin-plated copper alloy    |

## COLOURS

Standard



On request



