

MG1__-7,62-V

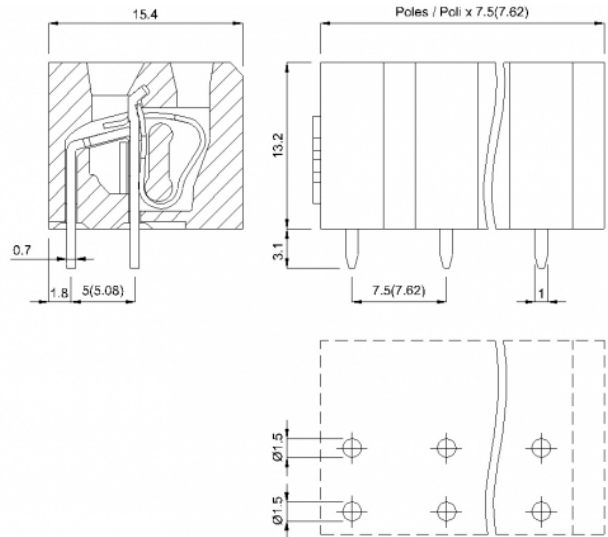
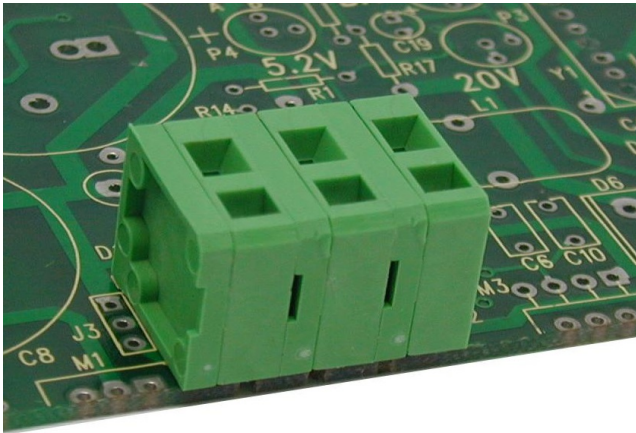

GENERAL INFORMATION

pitch	7,62 mm
Height	14.3 mm
Depth	16.75 mm
Dimensional class	Bassa
Wire section	2.5 mm ² / 14 AWG
Clamp opening size	2.45 x 2.45 mm
Wire stripping	max 9 mm
Operating temperature	-40 ÷ +130 °C

ELECTRICAL CHARACTERISTICS

Current	24 A
Voltage	450 V
impulse voltage	2 kV

MECHANICAL CHARACTERISTICS

Screw	-
Recommended torque	-

APPROVALS DATA



			UL 1059
Current	-	-	17 A factory / 17 A field
Voltage	-	-	300 V
Wire section	-	-	12 AWG
Torque	-	-	-
FILE	-	-	E178356

MATERIALS

Housing	PA - UL 94 V0
Screw	-
Spring	Spring steel
Terminal	Tin-plated copper alloy

COLOURS

Standard

On request

GN

GY

BK

BL

RD

YL

OG

POLES

NAME

3D FILE

02

MG102-7,62-V

File not available for this product