

# MG1\_\_-7,62-DI

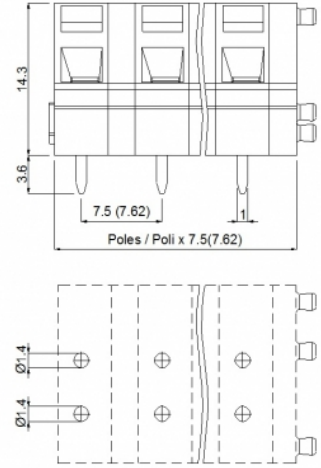
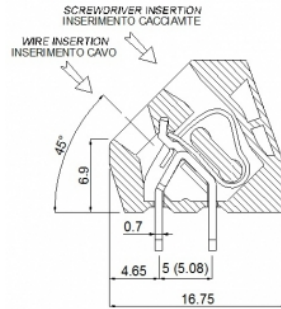

### GENERAL INFORMATION

pitch	7,62 mm
Height	14.3 mm
Depth	16.75 mm
Dimensional class	Bassa
Wire section	2.5 mm <sup>2</sup> / 14 AWG
Clamp opening size	2.45 x 2.45 mm
Wire stripping	max 9 mm
Operating temperature	-40 ÷ +130 °C

### ELECTRICAL CHARACTERISTICS

Current	24 A
Voltage	450 V
Test Voltage	2 kVrms/60s

### MECHANICAL CHARACTERISTICS

Screw	-
Recommended torque	-

### APPROVALS DATA



Current	-	-	<b>UL 1059</b>
Voltage	-	-	17 A factory / 17 A field
Wire section	-	-	300 V
Torque	-	-	12 ÷ 30 AWG
FILE	-	-	-
			E178356

### MATERIALS

Housing	PA - UL 94 V0
Screw	-

Spring  
Terminal

Spring steel  
Tin-plated copper alloy

**COLOURS**

Standard



On request



**POLES**

01

**NAME**

MG101-7,62-DI

**3D FILE**

File not available for this product